

Motion Control

FlexMotion™ -6C Hardware User Manual

Worldwide Technical Support and Product Information

www.natinst.com

National Instruments Corporate Headquarters

11500 North Mopac Expressway Austin, Texas 78759-3504 USA Tel: 512 794 0100

Worldwide Offices

Australia 03 9879 5166, Austria 0662 45 79 90 0, Belgium 02 757 00 20, Brazil 011 284 5011,
Canada (Ontario) 905 785 0085, Canada (Québec) 514 694 8521, China 0755 3904939, Denmark 45 76 26 00,
Finland 09 725 725 11, France 01 48 14 24 24, Germany 089 741 31 30, Hong Kong 2645 3186,
India 91805275406, Israel 03 6120092, Italy 02 413091, Japan 03 5472 2970, Korea 02 596 7456,
Mexico (D.F.) 5 280 7625, Mexico (Monterrey) 8 357 7695, Netherlands 0348 433466, Norway 32 27 73 00,
Singapore 2265886, Spain (Madrid) 91 640 0085, Spain (Barcelona) 93 582 0251, Sweden 08 587 895 00,
Switzerland 056 200 51 51, Taiwan 02 2377 1200, United Kingdom 01635 523545

For further support information, see the *Technical Support Resources* appendix. To comment on the documentation, send e-mail to techpubs@natinst.com.

© Copyright 1998, 1999 National Instruments Corporation. All rights reserved.

Important Information

Warranty

The FlexMotion-6C controllers are warranted against defects in materials and workmanship for a period of one year from the date of shipment, as evidenced by receipts or other documentation. National Instruments will, at its option, repair or replace equipment that proves to be defective during the warranty period. This warranty includes parts and labor.

The media on which you receive National Instruments software are warranted not to fail to execute programming instructions, due to defects in materials and workmanship, for a period of 90 days from date of shipment, as evidenced by receipts or other documentation. National Instruments will, at its option, repair or replace software media that do not execute programming instructions if National Instruments receives notice of such defects during the warranty period. National Instruments does not warrant that the operation of the software shall be uninterrupted or error free.

A Return Material Authorization (RMA) number must be obtained from the factory and clearly marked on the outside of the package before any equipment will be accepted for warranty work. National Instruments will pay the shipping costs of returning to the owner parts which are covered by warranty.

National Instruments believes that the information in this document is accurate. The document has been carefully reviewed for technical accuracy. In the event that technical or typographical errors exist, National Instruments reserves the right to make changes to subsequent editions of this document without prior notice to holders of this edition. The reader should consult National Instruments if errors are suspected. In no event shall National Instruments be liable for any damages arising out of or related to this document or the information contained in it.

EXCEPT AS SPECIFIED HEREIN, NATIONAL INSTRUMENTS MAKES NO WARRANTIES, EXPRESS OR IMPLIED, AND SPECIFICALLY DISCLAIMS ANY WARRANTY OF MERCHANTABILITY OR FITNESS FOR A PARTICULAR PURPOSE. CUSTOMER'S RIGHT TO RECOVER DAMAGES CAUSED BY FAULT OR NEGLIGENCE ON THE PART OF NATIONAL INSTRUMENTS SHALL BE LIMITED TO THE AMOUNT THEREOF PAID BY THE CUSTOMER. NATIONAL INSTRUMENTS WILL NOT BE LIABLE FOR DAMAGES RESULTING FROM LOSS OF DATA, PROFITS, USE OF PRODUCTS, OR INCIDENTAL OR CONSEQUENTIAL DAMAGES, EVEN IF ADVISED OF THE POSSIBILITY THEREOF. This limitation of the liability of National Instruments will apply regardless of the form of action, whether in contract or tort, including negligence. Any action against National Instruments must be brought within one year after the cause of action accrues. National Instruments shall not be liable for any delay in performance due to causes beyond its reasonable control. The warranty provided herein does not cover damages, defects, malfunctions, or service failures caused by owner's failure to follow the National Instruments installation, operation, or maintenance instructions; owner's modification of the product; owner's abuse, misuse, or negligent acts; and power failure or surges, fire, flood, accident, actions of third parties, or other events outside reasonable control.

Copyright

Under the copyright laws, this publication may not be reproduced or transmitted in any form, electronic or mechanical, including photocopying, recording, storing in an information retrieval system, or translating, in whole or in part, without the prior written consent of National Instruments Corporation.

Trademarks

BridgeVIEW™, CVI™, FlexCommander™, FlexMotion™, LabVIEW™, natinst.com™, and National Instruments™ are trademarks of National Instruments Corporation.

Product and company names mentioned herein are trademarks or trade names of their respective companies.

WARNING REGARDING MEDICAL AND CLINICAL USE OF NATIONAL INSTRUMENTS PRODUCTS

National Instruments products are not designed with components and testing for a level of reliability suitable for use in or in connection with surgical implants or as critical components in any life support systems whose failure to perform can reasonably be expected to cause significant injury to a human. Applications of National Instruments products involving medical or clinical treatment can create a potential for death or bodily injury caused by product failure, or by errors on the part of the user or application designer. Because each end-user system is customized and differs from National Instruments testing platforms and because a user or application designer may use National Instruments products in combination with other products in a manner not evaluated or contemplated by National Instruments, the user or application designer is ultimately responsible for verifying and validating the suitability of National Instruments products whenever National Instruments products are incorporated in a system or application, including, without limitation, the appropriate design, process and safety level of such system or application.

Contents

About This Manual

Conventions	ix
Related Documentation.....	x

Chapter 1

Introduction

About the FlexMotion-6C Controllers.....	1-1
What You Need to Get Started	1-2
Software Programming Choices	1-3
National Instruments Application Software	1-3
Optional Equipment	1-4
Motion Signal and Motion I/O Connections.....	1-4

Chapter 2

Configuration and Installation

Software Installation.....	2-1
Controller Configuration.....	2-1
PC-FlexMotion-6C Controllers	2-2
PCI-FlexMotion-6C Controllers.....	2-2
Hardware Installation.....	2-2

Chapter 3

Hardware Overview

User Connectors	3-2
Test Connectors	3-3
ISA Bus Address Table (PC-FlexMotion-6C Only).....	3-3
Motion I/O Configuration	3-7
Selecting an Isolated External/Internal Voltage Supply Configuration	3-8
Locating the Isolated Supply Jumper Block JP2	3-8
How to Set the Isolated Supply Jumpers (JP2) for	
Internal +5 V Supply	3-8
How to Set the Isolated Supply Jumpers (JP2) for	
External Isolated Supply (+ISO).....	3-9
RP3 and RP10 DIP Resistor Networks	3-10
Selecting Encoder Termination Networks.....	3-11

Chapter 4 Functional Overview

Dual Processor Architecture.....	4-1
Embedded Real-Time Operating System (RTOS).....	4-1
Enhanced PID Functions.....	4-2
Trajectory Generators	4-2
Trapezoidal Point-to-Point Position Control	4-3
Velocity Control	4-3
Move Blending	4-3
Electronic Gearing	4-4
Linear and Circular Interpolation	4-4
Analog Feedback.....	4-5
Flash Memory	4-5
Axes, Motion Resources, and Vector Spaces	4-6
Axes	4-6
Motion Resources	4-7
Vector Spaces.....	4-8
Onboard Programs.....	4-9
Find Home and Find Index	4-10
Find Home	4-10
Find Index.....	4-10
Host Communications	4-11
Packets, Handshaking, and FIFO Buffers.....	4-11
Return Data Buffer.....	4-12
Error Stack	4-13

Chapter 5 Signal Connections

Motion I/O Connector	5-1
Motion Axis Signals.....	5-4
Limit and Home Inputs	5-5
Wiring Concerns.....	5-7
Limit and Home Input Circuit	5-7
Encoder Signals.....	5-7
Wiring Concerns.....	5-9
Encoder Input Circuit	5-10
Trigger Inputs and Breakpoint Outputs	5-11
Wiring Concerns.....	5-12
Trigger Input and Breakpoint Output Circuits	5-12

Analog Inputs	5-13
Wiring Concerns	5-13
Other Motion I/O Connections	5-14
Auxiliary 24-Bit Digital I/O Connector	5-14
PWM Features	5-17

Appendix A Specifications

Appendix B Cable Connector Descriptions

Appendix C Technical Support Resources

Glossary

Index

Figures

Figure 3-1.	PC-FlexMotion-6C Parts Locator Diagram	3-1
Figure 3-2.	PCI-FlexMotion-6C Parts Locator Diagram	3-2
Figure 3-3.	Factory-Default DIP Switch Setting.....	3-4
Figure 3-4.	Internal +5 V Supply Configuration, Limit Switch Connection Example	3-9
Figure 3-5.	External Voltage Supply Configuration, Limit Switch Connection Example	3-10
Figure 3-6.	Optocoupled Motion I/O DIP Resistor Networks	3-11
Figure 3-7.	Encoder Input Termination SIP Resistor Networks	3-12
Figure 4-1.	Servo Axis Resources.....	4-6
Figure 4-2.	Stepper Axis Resources.....	4-6
Figure 4-3.	3D Vector Space.....	4-8
Figure 5-1.	100-Pin Motion I/O Connector Pin Assignment	5-2
Figure 5-2.	Limit and Home Input Circuit	5-7
Figure 5-3.	Quadrature Encoder Phasing Diagram	5-9
Figure 5-4.	Encoder Input Circuit	5-10
Figure 5-5.	Trigger Input Circuit	5-12
Figure 5-6.	Breakpoint Output Circuit	5-12

Figure 5-7.	50-Pin Digital I/O Connector Pin Assignments	5-15
Figure 5-8.	Auxiliary 24-Bit Digital I/O Port Configuration	5-16
Figure B-1.	First 50-Pin Motion I/O Connector Pin Assignment	B-2
Figure B-2.	Second 50-Pin Motion I/O Connector Pin Assignment	B-3

Tables

Table 3-1.	ISA Bus Address Map	3-4
Table 3-2.	Motion I/O Resistor Values	3-11
Table 3-3.	Encoder Termination Resistor Values	3-12
Table 5-1.	Motion I/O Signal Connections	5-3
Table 5-2.	Enhanced I/O Features	5-17

About This Manual

This manual describes the electrical and mechanical aspects of each controller in the FlexMotion-6C family of motion controllers and contains information concerning their operation and programming. Unless otherwise noted, text applies to all controllers in the FlexMotion-6C family.

The FlexMotion-6C family of motion controllers includes the following controllers:

- PC-FlexMotion-6C
- PCI-FlexMotion-6C

The FlexMotion-6C controllers are high-performance motion controllers for ISA and PCI bus computers.

Conventions

The following conventions appear in this manual:

<>

Angle brackets that contain numbers separated by an ellipsis represent a range of values associated with a bit or signal name—for example, DBIO<3..0>.



This icon denotes a note, which alerts you to important information.



This icon denotes a caution, which advises you of precautions to take to avoid injury, data loss, or a system crash.



This icon denotes a warning, which advises you of precautions to take to avoid being electrically shocked.

italic

Italic text denotes variables, emphasis, a cross reference, or an introduction to a key concept. This font also denotes text that is a placeholder for a word or value that you must supply.

bold

Bold text denotes items that you must select or click on in the software, such as menu items and dialog box options. Bold text also denotes parameter names.

FlexMotion-6C

Refers to the PC-FlexMotion-6C and the PCI-FlexMotion-6C motion controllers.

FlexMotion
software reference

Refers to both the *FlexMotion Software Reference Manual* and the *FlexMotion Software Reference Online Help*.

Related Documentation

The following documents contain information you may find helpful as you read this manual:

- *FlexMotion Software Reference Manual*
- *FlexMotion Software Reference Online Help*
- *FlexMotion VI Online Help*
- *PCI Local Bus Specification*, Revision 2.1
- Your computer's technical reference manual

Introduction

This chapter describes the FlexMotion-6C controllers and their operation.

About the FlexMotion-6C Controllers

Thank you for purchasing a FlexMotion-6C motion controller. FlexMotion-6C controllers have advanced motion control performance along with easy-to-use software tools and add-on motion VI libraries for use with LabVIEW and BridgeVIEW—LabVIEW for Industrial Automation.

The FlexMotion-6C line of motion controllers are a combination of servo and stepper motor controllers for ISA and PCI bus computers. These controllers provide fully programmable motion control for up to six independent or coordinated axes of motion, with dedicated motion I/O for limit and home switches and additional I/O for general-purpose functions. You can configure up to two of the axes for stepper motor control. You can use these controllers for all position and velocity control applications including the following:

- Point-to-point positioning
- Velocity profiling
- 3-D Linear interpolation
- Electronic gearing
- Circular, helical, and spherical interpolation
- Time-based motion integration
- Vector space motion

Servo axes can control servo motors, servo hydraulics, servo valves, and other servo devices. Servo axes always operate in closed-loop mode. These axes use quadrature encoders or analog inputs for position and velocity feedback and provide analog command outputs with an industry-standard range of ± 10 V. FlexMotion-6C can also be configured for up to two stepper axes to control stepper motors. These axes can operate in open or closed-loop mode. They use quadrature encoders for position and velocity feedback (closed-loop only), and provide step/direction or clockwise (CW)/counter-clockwise (CCW) digital command outputs. All stepper axes support full, half, and microstepping applications.

FlexMotion-6C's high-performance capabilities are the result of an advanced dual-processor architecture using a Motorola MC68331 real-time 32-bit CPU combined with an Analog Devices ADSP-2111 digital signal processor (DSP) and custom field programmable gate arrays (FPGA). Its first-in-first-out (FIFO) bus interface and powerful function set provide high-speed communications while offloading complex motion functions from the host PC for optimum command throughput and system performance.

You can use FlexMotion-6C's full onboard programming to execute up to 10 simultaneous motion programs in a preemptive, real-time multitasking operating system environment.

Motion profiles are controlled with enhanced PID/PIVff servo updates at 62 μ s per axis and encoder feedback rates up to 16 MHz. Each axis has optoisolated motion I/O for end-of-travel limit and home switch inputs, breakpoint output, and trigger input. FlexMotion-6C controllers also have non-dedicated user I/O including 24 bits of digital I/O and eight analog inputs for ± 10 V signals, providing motion PID feedback for loop closure, joystick inputs, or coarse monitoring of analog sensors.

What You Need to Get Started

To set up and use your FlexMotion-6C controller, you will need the following:

- One of the FlexMotion-6C controllers:
 - PC-FlexMotion-6C
 - PCI-FlexMotion-6C
- FlexMotion-6C Hardware User Manual*
- FlexMotion Software Reference Manual*
- One of the following software packages and documentation:
 - LabVIEW
 - LabWindows/CVI
 - BridgeVIEW
 - FlexMotion software (includes FlexCommander)
- Your computer with an available ISA or PCI slot as appropriate.

Software Programming Choices

You have several options to choose from when programming your National Instruments FlexMotion-6C controller. You can use National Instruments application software, FlexMotion VIs for LabVIEW and BridgeVIEW, or the FlexMotion software.

Programming the FlexMotion-6C controller is straightforward using a simple but powerful high-level function set application programming interface (API). All setup and motion control functions are easily executed by calling into either a static or dynamically linked library (DLL). These libraries are callable from C, Visual Basic, and other high-level languages. Full function set implementations are available for LabVIEW, LabWindows/CVI, BridgeVIEW, and other industry-standard software programs.

National Instruments Application Software

LabVIEW and BridgeVIEW, based on the graphical programming language G, feature interactive graphics and a state-of-the-art user interface. In LabVIEW and BridgeVIEW, you can create 32-bit compiled programs and stand-alone executables for custom automation, data acquisition, test, measurement, and control solutions. National Instruments offers the FlexMotion VI Library, a series of virtual instruments (VIs) for using LabVIEW and BridgeVIEW with National Instruments motion control hardware. The Motion VI library implements the full function set API and a powerful set of demo functions, example programs, and fully operational, high-level application routines.

ANSI C-based LabWindows/CVI also features interactive graphics and a state-of-the-art user interface. Using LabWindows/CVI, you can generate C code for custom data acquisition, test, and all measurement and automation solutions. The FlexMotion software includes a series of sample programs for using LabWindows/CVI with National Instruments motion control hardware.

Optional Equipment

National Instruments offers a variety of products to use with FlexMotion-6C controllers, including cables, Universal Motion Interfaces (UMIs), drive units, and other accessories, as follows:

- Cables and cable assemblies
- UMI wiring connectivity blocks with integrated motion signal conditioning and motion inhibit functionality
- Servo motor compatible driver amplifier units with integrated power supply and wiring connectivity
- Connector blocks, shielded and unshielded 50-pin screw terminal wiring aids

Refer to Appendix C, *Technical Support Resources*, or visit our online catalog at www.natinst.com for information on how to contact National Instruments for specific information about these products.

Motion Signal and Motion I/O Connections

The external motion I/O connector on the FlexMotion-6C controllers is a 100-pin female, right-angle, metal shell-type connector.

The auxiliary 24-bit digital I/O connector is a 50-pin male, box-header connector.

You can use any compatible mating connector. Mating connector types include insulation displacement ribbon cable connectors and discrete wire mating connectors.

Configuration and Installation

This chapter describes how to configure and install your FlexMotion-6C controller.

Software Installation

Install your FlexMotion software, along with your Motion VI libraries (if appropriate) before you install the FlexMotion-6C controller. Refer to the release notes included with your FlexMotion-6C controller for specific instructions on the software installation sequence for your host PC.

Controller Configuration

There are two types of required configuration to be performed on the FlexMotion-6C controllers before they are installed in the host computer—bus-related configuration and motion I/O-related configuration.

The motion I/O-related configuration consists of setting the isolated voltage supply jumpers to configure the optoisolated I/O for internal (non-isolated +5 V) or external isolated (+ISO) supply.

Your FlexMotion-6C has full optoisolation on the motion I/O signals, but you can forgo the isolation and the need for an external supply by using the computer's internal +5 V supply to power the I/O circuits. Refer to Chapter 3, [Hardware Overview](#), for information on setting the isolated voltage supply jumpers.

The bus-related configuration is different for each bus type (ISA or PCI) of FlexMotion-6C controller.

PC-FlexMotion-6C Controllers

The PC-FlexMotion-6C controllers may occupy any available 16-bit ISA slot in the host computer. The bus communication address of the FlexMotion-6C controller is set with a DIP switch located on the controller. See Chapter 3, *Hardware Overview*, for more information on setting the address DIP switch. You can install multiple PC-FlexMotion-6C controllers, with different address selections for each, in the host computer.

PCI-FlexMotion-6C Controllers

The PCI-FlexMotion-6C controller is fully compatible with the *PCI Local Bus Specification*, Revision 2.1. This compatibility allows the computer to automatically perform all bus-related configuration and requires no user interaction. There are no jumpers to configure for bus-related configuration.



Note Refer to the release notes included with your software for information on assigning a controller's board ID and verifying the bus address of your controller.

Hardware Installation

You can install the FlexMotion-6C controller in any open compatible ISA or PCI expansion slot in your computer. The typical power required for each FlexMotion-6C controller is given in Appendix A, *Specifications*.

The following are general installation instructions, but consult your computer user manual or technical reference manual for specific instructions and warnings.



Caution flexmotion-6c controllers are sensitive electronic devices shipped in an antistatic bag. open only at an approved workstation and observe precautions for handling electrostatic-sensitive devices.

1. Turn off and unplug your computer.
2. Remove the top cover or access port to the ISA or PCI expansion slots in your computer.
3. Remove the expansion slot connector port cover on the back panel of the computer if installed.
4. Insert the FlexMotion-6C controller into a +5 V ISA or PCI slot as appropriate. Gently rock the controller to ease it into place. It may be a tight fit, but do not force the controller into place.

5. If available, screw the mounting bracket of the FlexMotion-6C controller to the back panel rail of the computer.
6. Replace the cover.
7. Plug in the 100-pin cable for motion I/O to the FlexMotion-6C controller.
8. Plug in and turn on your computer.

Your PC/PCI-FlexMotion-6C controller is installed.

Hardware Overview

This chapter presents an overview of the hardware functionality on the FlexMotion-6C controller. The FlexMotion-6C controller comes in two versions:

- PC-FlexMotion-6C for ISA bus computers
- PCI-FlexMotion-6C for PCI bus computers

Figures 3-1 and 3-2 show the PC-FlexMotion-6C and PCI-FlexMotion-6C parts locator diagrams.

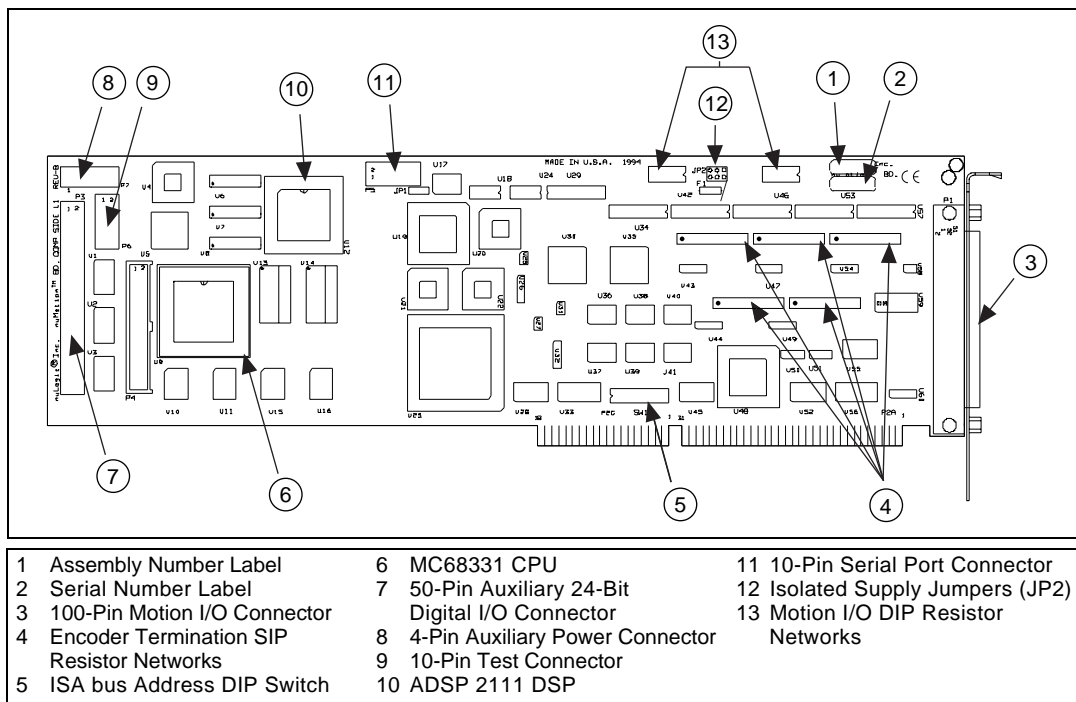

Figure 3-1. PC-FlexMotion-6C Parts Locator Diagram

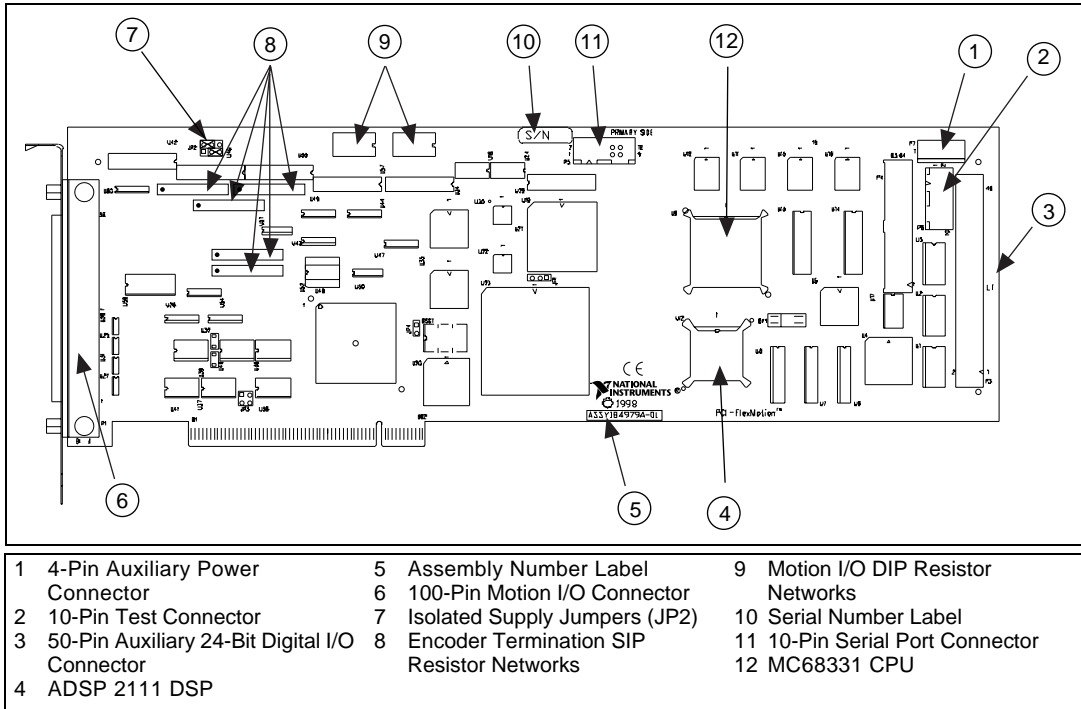

Figure 3-2. PCI-FlexMotion-6C Parts Locator Diagram

User Connectors

The 100-pin motion I/O connector provides all of the signals for the six axes of closed-loop motion control including encoder feedback, limit and home inputs, breakpoint outputs, trigger inputs and A/D converter signals. Refer to Chapter 5, *Signal Connections*, for the complete details of the signals in the motion I/O connector.

The 50-pin auxiliary 24-bit digital I/O connector provides an Opto 22-compatible interface to 24 bits of user-configured digital I/O. Refer to Chapter 5, *Signal Connections*, for the complete details of the signals in the auxiliary 24-bit digital I/O connector.

Test Connectors

The 10-pin test connector is a proprietary interface for production testing and troubleshooting. Do not plug anything into this connector.



Note Misuse of the reserved connectors may seriously damage the FlexMotion-6C controller. Unauthorized use of the reserved connectors will void any warranty coverage for the product.

With the FlexMotion-6C controller properly installed, only two connectors are typically used—the 100-pin motion I/O connector and the 50-pin auxiliary 24-bit digital I/O connector. You use cables and accessories to connect to your motion system.

Interface accessories for the FlexMotion-6C family vary from the enhanced Universal Motion Interface (UMI) units with signal conditioning and pluggable screw terminal connectors to simple screw terminal blocks. Drive units are available to supply pluggable connectors, power supplies, amplifier/drivers, and direct motion system interfacing capabilities.

ISA Bus Address Table (PC-FlexMotion-6C Only)

For backward compatibility with non-Plug-and-Play computers, the PC-FlexMotion-6C controller has an onboard DIP switch-selectable address setting. You must set the desired address for all communications with the FlexMotion-6C controller prior to inserting the controller into the computer.

The ISA bus is designed to support many peripheral device controllers as long as all of the controllers have different, distinct ISA bus addresses. You must use an address that is not currently used by another controller to avoid conflict during host communications and the potential for faulty operation. Set the controller address using the DIP switch as shown in Figure 3-1.

Table 3-1 lists the possible base addresses for the PC-FlexMotion-6C, along with the corresponding settings for the address selector DIP switch. All addresses in this table are hexadecimal. Positions 1 through 6 are used for setting the base address. Positions 7 and 8 are used for internal test and must be left off.

Write down the base I/O address that you select and the DIP switch configuration. This information will be used for further configuration, controller board ID verification, and for future reference of this address from software.



Caution DIP switch positions 7 and 8 must be off for the PC-FlexMotion-6C to function properly.

The factory-default base address for your controller is 0x3E0, as shown in Figure 3-3.

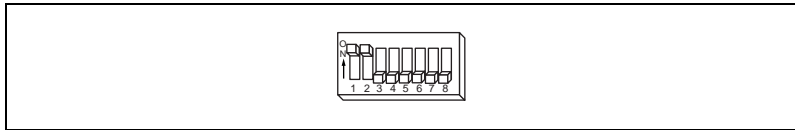

Figure 3-3. Factory-Default DIP Switch Setting









Note For Windows 3.1 and DOS Users: Certain addresses that are typically used for host computer functions such as serial and parallel I/O ports and display adapters are indicated in the following list. However, since not all manufacturers use these standards, please verify that an address is truly available and not used before setting the PC-FlexMotion-6C DIP switch to that address.

For Windows 2000/NT/98/95 Users: Controller address selection is determined by registry control within the operating system. Refer to the release notes included with your FlexMotion-6C controller for step-by-step instructions for installing under these operating systems.

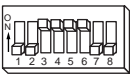
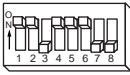
Table 3-1. ISA Bus Address Map

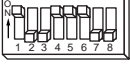
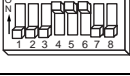
Base Address	DIP Switch Address	Typical Use ¹	Base Address	DIP Switch Address	Typical Use ¹
200		Game I/O	258		
208			260		
210			268		

Table 3-1. ISA Bus Address Map (Continued)

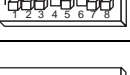
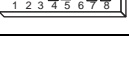
Base Address	DIP Switch Address	Typical Use ¹
218		
220		
228		
230		
238		
240		
248		
250		
2B0		
2B8		
2C0		











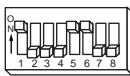

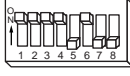

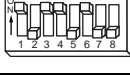
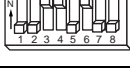
Base Address	DIP Switch Address	Typical Use ¹
270		
278		Parallel Port 2
280		
288		
290		
298		
2A0		
2A8		
308		Prototype Card
310		Prototype Card
318		Prototype Card

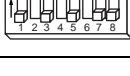
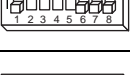
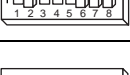
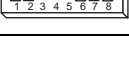
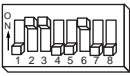
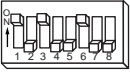
Table 3-1. ISA Bus Address Map (Continued)

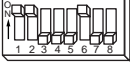
Base Address	DIP Switch Address	Typical Use ¹
2C8		
2D0		
2D8		
2E0		
2E8		Serial Port 4
2F0		
2F8		Serial Port 2
300		Prototype Card
360		PC Network
368		PC Network
370		

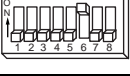
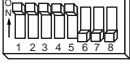









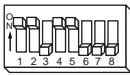
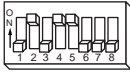



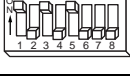

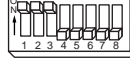

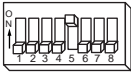
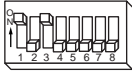
Base Address	DIP Switch Address	Typical Use ¹
320		
328		
330		
338		
340		
348		
350		
358		
3B8		Monochrome/ Printer
3C0		EGA/VGA Adapter
3C8		EGA/VGA Adapter

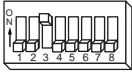
Table 3-1. ISA Bus Address Map (Continued)

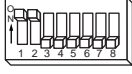
Base Address	DIP Switch Address	Typical Use ¹	Base Address	DIP Switch Address	Typical Use ¹
378		Parallel Port 1	3D0		CGA/MCGA Adapter
380		SDLC/ Bisynchronous	3D8		CGA/MCGA Adapter
388		SDLC/ Bisynchronous	3E0		Factory Default
390			3E8		Serial Port 3
398			3F0		Diskette Controller
3A0		Bisynchronous 1	3F8		Serial Port 1
3A8		Bisynchronous 1	¹ Blank table cells indicate this base address is typically available for plug-in controllers.		
3B0		Monochrome/ Printer			

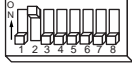
Motion I/O Configuration

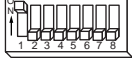
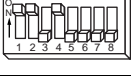
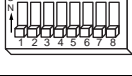
The FlexMotion-6C controller has a number of user-configurable components shown previously in Figures 3-1 and 3-2. You can use these components to tailor and optimize the motion I/O circuits to satisfy specific application requirements. All of these user-configurable components are mounted in sockets for easy replacement in the field. The FlexMotion-6C controller ships with an accessory pack that includes an appropriate assortment of single inline package (SIP) and dual inline package (DIP) resistor networks and jumpers.

Selecting an Isolated External/Internal Voltage Supply Configuration

The FlexMotion-6C controller provides optoisolation on the motion I/O signals. Isolated I/O reduces noise sensitivity by breaking ground loops and isolating the FlexMotion-6C and host PC's ground from field sensors and external device ground wiring. These optocoupled signals include forward, reverse, and home limit inputs, trigger inputs, breakpoint outputs, and E-Stop input.

Optocoupled signals require a power supply to power the isolation circuits. If your motion system uses optoisolation for limits and/or other motion I/O, it is necessary to supply an external isolated voltage source (+ISO), on the 100-pin connector to power these isolated I/O circuits. Alternatively, you can forgo the optoisolation and set onboard jumpers to use the computer's internal +5 V supply to power the motion I/O circuits. In this case, the motion I/O signals will be non-isolated.

Locating the Isolated Supply Jumper Block JP2

Refer to Figures 3-1 and 3-2 for the location of the isolated supply jumper block (JP2). You use this 6-pin jumper block to select between the computer's internal +5 V supply or an external isolated (+ISO) power source for the FlexMotion-6C optocoupled circuitry.



Note The FlexMotion-6C isolated supply jumpers are factory configured for external isolated voltage source, and motion I/O will not function properly until a +ISO voltage is supplied, or the jumpers are reconfigured to use the internal +5 V supply.

How to Set the Isolated Supply Jumpers (JP2) for Internal +5 V Supply

To use the internal +5 V supply for isolated (+ISO) and isolated return (ISORTN), place the jumpers on jumper block JP2 as shown in Figure 3-4. You must also change DIP resistor networks RP3 and RP10 from 2.2 k Ω to 470 Ω . The appropriate DIP resistor networks are included in the FlexMotion-6C accessory pack that ships with the controller.

When changing networks, be careful to install the resistor network with the correct pin 1 orientation. You can then connect your limit and home switches between the limit or home input and the ISORTN (ground-referenced) signals on the 100-pin motion I/O connector.

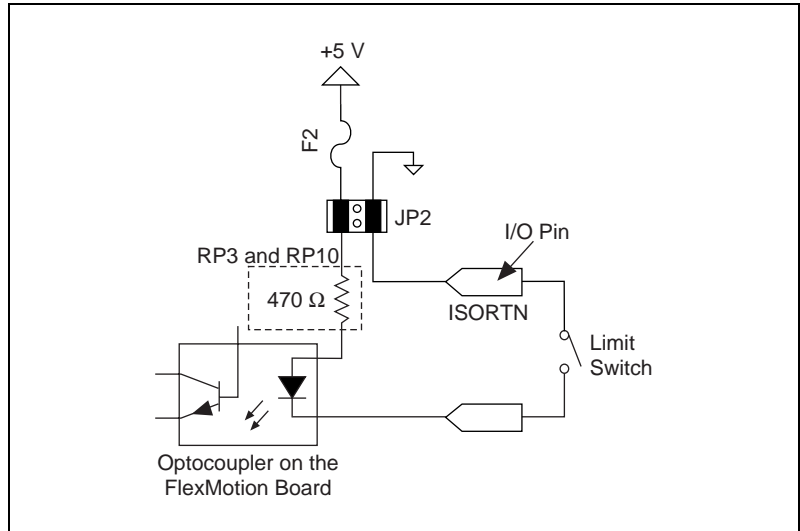

Figure 3-4. Internal +5 V Supply Configuration, Limit Switch Connection Example



Caution Do not connect an external voltage source to the +ISO or ISORTN signals on the 100-pin motion I/O connector if you have the jumpers set for internal +5 V supply. When the jumpers are set for internal +5 V, the I/O circuitry uses voltages already present on the FlexMotion-6C controller. Improper signal connections can damage the FlexMotion-6C controller and void the warranty.

How to Set the Isolated Supply Jumpers (JP2) for External Isolated Supply (+ISO)

To configure the motion I/O circuits to use an external voltage source for +ISO and ISORTN, place the jumpers on jumper block JP2, as shown in Figure 3-5. The FlexMotion-6C controller comes factory configured for +18 to +24 V external isolated supply with DIP resistor networks RP3 and RP10 set at 2.2 kΩ (refer to the following section, *RP3 and RP10 DIP Resistor Networks*, for more information on DIP resistor value and +ISO voltage range selection). Apply a positive voltage (+24 V maximum) from an external supply to the +ISO input, connect the ISORTN to the external isolated supply return (ground) and connect the limit or home switch between the limit or home input and the ISORTN ground on the 100-pin motion I/O connector.

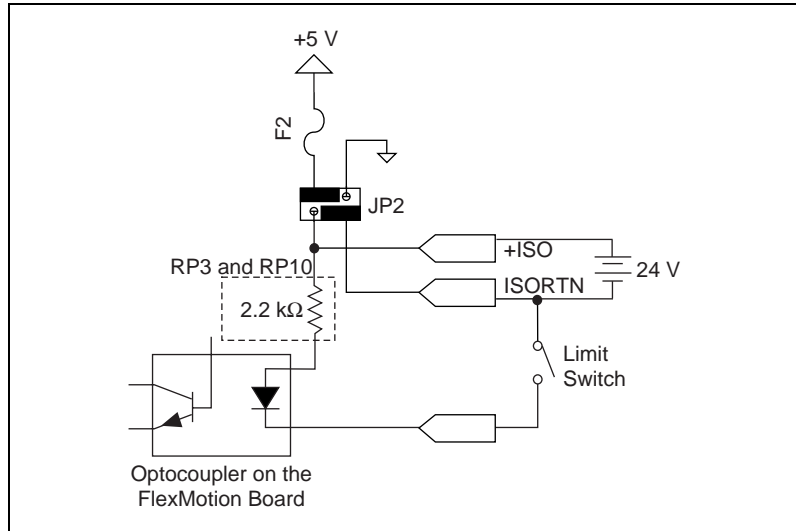

Figure 3-5. External Voltage Supply Configuration, Limit Switch Connection Example

RP3 and RP10 DIP Resistor Networks

The DIP resistor networks RP3 and RP10 provide the current source for the optocoupled inputs and the pull-ups for the optocoupled outputs, as shown in Figure 3-6. One end of these resistors is connected to the +ISO voltage source and the other end is connected to the individual input or output signal, via the optocoupler component.

The correct operating value of these resistor networks depends upon the external isolated supply voltage used. The FlexMotion-6C controller ships with 2.2 kΩ networks installed in RP3 and RP10 for use with +24 V external isolated supplies. If a different value is needed, you can change these networks by removing them from their sockets and replacing them with the appropriate value network.



Note When changing networks, be careful to install the correct resistor network value, for the +ISO voltage supplied, with the correct pin 1 orientation in the socket.

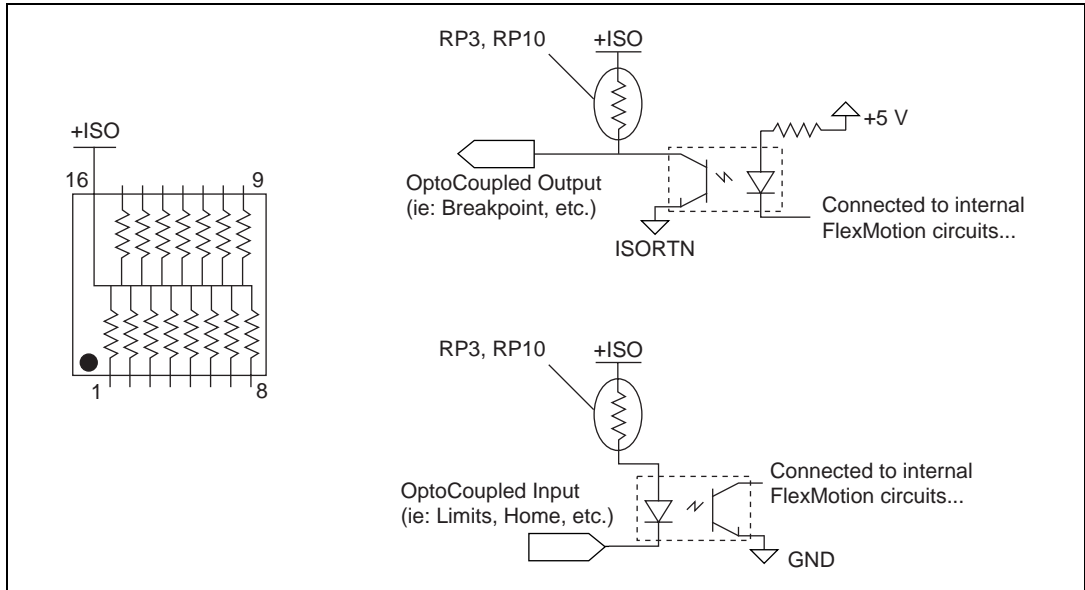

Figure 3-6. Optocoupled Motion I/O DIP Resistor Networks

Table 3-2 shows the correct DIP resistor values for each range of external (and internal) isolated supply voltage.

Table 3-2. Motion I/O Resistor Values

Isolated Supply Voltage	DIP Resistor Network
5 V, internal	470 Ω
5 to 12 V, external	470 Ω
10 to 18 V, external	1 k Ω
18 to 24 V, external	2.2 k Ω (factory default)



Note The resistor networks used for RP3 and RP10 are 16-pin DIP packages with 15 resistors, based pull-up networks, Bourns part number 4116R-002-RRR or equivalent (RRR = resistor value).

Selecting Encoder Termination Networks

FlexMotion-6C offers high-speed differential or single-ended encoder inputs with user-configurable termination for optimum encoder signal performance. The termination is provided by SIP resistor networks RP6, RP8, RP11, RP13, and RP15. These networks are dual-termination networks. The terminated

encoder signals are pulled up to +5 V and pulled down to GND through appropriate resistance values, as shown in Figure 3-7.

The recommended values for these terminator resistor SIP networks is dependent upon two primary factors: the maximum frequency of the encoder input signals, and the presence or lack of a differential line driver at the encoder source end. The FlexMotion-6C accessory pack shipped with the controller includes appropriate SIP resistor networks.



Note When changing networks, be careful to install the correct resistor network with the correct pin 1 orientation in the socket.

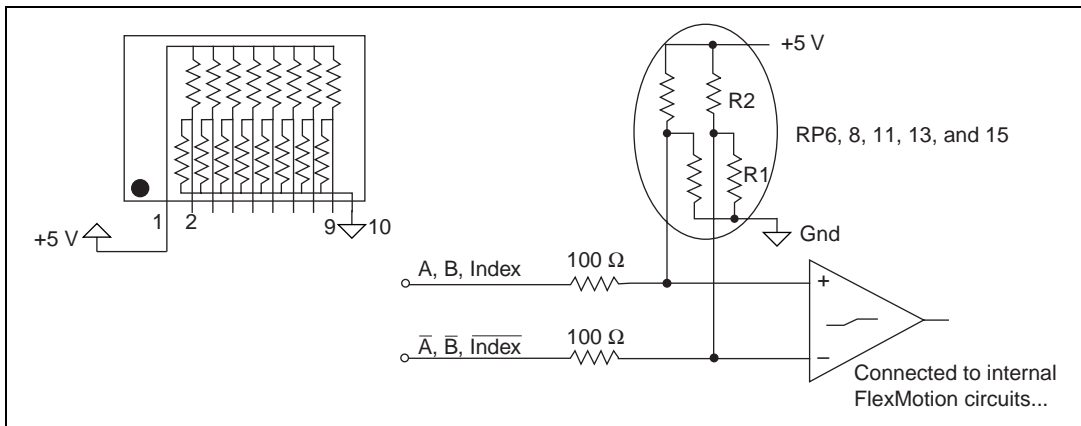

Figure 3-7. Encoder Input Termination SIP Resistor Networks

Table 3-3 lists the recommended termination networks for various encoder types.

Table 3-3. Encoder Termination Resistor Values

Encoder Type	SIP Termination Resistor Network R1/R2
Differential, ≥ 1 MHz	180/390 Ω (factory default)
Differential, < 1 MHz	1.5/3.3 k Ω
Single ended	1.5/3.3 k Ω



Note The resistor networks used for RP6, RP8, RP11, RP13, and RP15 are 10-pin SIP packages with eight channel, dual-termination resistor networks, Bourns part number 4610X-104-RRR/RRR or equivalent (R1/R2 = resistor values).

Functional Overview

This chapter presents an overview of the motion control algorithms and embedded firmware functionality on the FlexMotion-6C controller.

Dual Processor Architecture

The FlexMotion-6C controller allows you to perform up to six axes of simultaneous, coordinated motion control in a preemptive multitasking, real-time environment.

FlexMotion-6C's high-performance capabilities result from an advanced dual-processor architecture using a Motorola MC68331 real-time 32-bit CPU combined with an Analog Devices ADSP 2111 DSP and custom FPGAs. Its FIFO bus interface and powerful function set provide high-speed communications while off-loading complex motion functions from the host PC for optimized system performance.

FlexMotion-6C uses the digital signal processor for all closed-loop control including position tracking, PID control closed-loop computation, and motion trajectory generation. The DSP chip is supported by custom FPGAs and I/O processors that perform the high-speed encoder interfacing, position capture and breakpoint functions, motion I/O processing, and stepper pulse generation for hard real-time functionality.

The embedded, multitasking real-time CPU handles host communications, command processing, multi-axis interpolation, onboard program execution, error handling, general-purpose digital I/O, and overall motion system integration functions.

Embedded Real-Time Operating System (RTOS)

The embedded firmware is based upon the RTXC embedded RTOS kernel for optimum system performance in varying motion applications. Motion tasks are prioritized. Task execution order depends upon its priority, the state of the entire motion system, I/O or other system events, and the real-time clock.

The DSP chip, being a separate processor, operates independently from the CPU but is closely synchronized by an internal packet-based command, data, and messaging event structure. FlexMotion-6C is truly a multiprocessing as well as a multitasking embedded controller.

Enhanced PID Functions

The DSP chip implements an enhanced PID/PIVff closed-loop servo control algorithm. PID update rates are user-programmable and can be as fast as 62 μ s per axis. The trajectory generators calculate the instantaneous desired position in each PID update period for unsurpassed trajectory control and smoothness. On stepper axes, the DSP chip services the stepper pulse generators each update period, resulting in accurate step pulse frequency outputs.

In addition to the standard PID loop control terms, FlexMotion-6C adds the following features:

- An integration limit value to minimize the effects of integrator windup, by limiting the contribution on the integral sum
- A derivative sample time multiplier to minimize quantization induced torque noise, and control the effect of the derivative gain
- Velocity and acceleration feedforward for following error minimization
- A velocity estimator and feedback gain for improved low-speed smoothness

FlexMotion-6C also supports dual-loop feedback configurations where the primary sensor is used for position feedback and the secondary feedback is used for velocity estimation and feedback damping.



Note Refer to the *Axis and Resource Configuration* section of the FlexMotion software reference for more information on enhanced PID and dual-loop feedback functions.

Trajectory Generators

FlexMotion-6C trajectory generators are responsible for calculating the instantaneous position command that controls acceleration and velocity while it moves the axis to its target position. This command is then sent to the PID servo loop or stepper pulse generator, depending on axis configuration.

To implement infinite trajectory control, FlexMotion-6C has 12 trajectory generators implemented in the DSP chip, two per axis. Each generator

calculates an instantaneous position each PID update period. While simple point-to-point moves require only one trajectory generator, two simultaneous generators are required for unsurpassed blended move and infinite trajectory control processing.

The following sections describe the five primary trajectory types supported by the FlexMotion-6C controller.

Trapezoidal Point-to-Point Position Control

Like virtually all motion controllers, FlexMotion-6C implements trapezoidal profile control for point-to-point moves. FlexMotion-6C has enhanced the trapezoidal profile to offer independent acceleration and deceleration value programming and S-curve smoothing (jerk control) of the acceleration/deceleration inflection points.

Motion occurs first with a programmable acceleration (smoothed by the S-curve value), then for a period at a constant velocity (if required) and then with a programmed deceleration, stopping at the desired target position. You can interrupt motion by executing a stop or kill motion function. Motion is automatically halt-stopped if an enabled limit or home input signal becomes active during the move.



Note Refer to the *FlexMotion Software Reference* for more information on the programming of trapezoidal trajectory control parameters.

Velocity Control

Velocity control is a simple variation of trapezoidal position control. The same trajectory generator implements a continuous velocity control mode. If you select this mode, the target position is effectively set to infinity and the axis moves at the programmed constant velocity. You can change velocity on the fly and all existing acceleration, deceleration, and S-curve limits are in effect during the velocity transition. You can interrupt motion by executing a stop or kill function. Motion is automatically halt-stopped if an enabled limit or home input signal becomes active. This mode is useful for jogging moves, simple speed control, and continuous contouring motion applications.

Move Blending

You can use the FlexMotion-6C controller to blend moves together with a programmable blend factor. Using the user-defined blend factor, the FlexMotion-6C DSP chip starts a second trajectory generator with the second move on an axis while the first trajectory generator is still

decelerating from the previous trajectory move. The two-position command outputs are combined digitally by superposition. You can use FlexMotion-6C's infinite trajectory control processing to automatically and smoothly blend any move type into any other move without stopping the axis or axes involved.



Note Refer to the *FlexMotion Function Reference* for more information on blending and blend factors.

Electronic Gearing

With electronic gearing, you can slave both position and velocity on one or more axes to a master position/velocity source for synchronous ratio-based motion. The master can be the feedback of an axis, an independent encoder input or ADC channel, or even the trajectory generator output of another axis.

A slave axis operates in a special mode that calculates an instantaneous position command value that is a ratio of the master position. Since this calculation is completed every PID update, the axis accurately tracks the ratio of the master position velocity. For example, setting a gear ratio of 3:2 results in the slave axis rotating three revolutions for every two revolutions of the master. Each slave axis can have its own gear ratio independent and relative to the master axis.

You can also superimpose any move type on top of the geared slave because its trajectory generators are not used for gearing. Again, the target position command values are combined digitally using superposition. This very powerful feature allows registration moves in an electronically geared, master/slave system.



Note Refer to the *FlexMotion Software Reference* for more information on electronic master/slave gearing.

Linear and Circular Interpolation

You can synchronize and control multiple axes to perform 2D and 3D linear interpolation, 2D circular interpolation, and 3D helical and spherical interpolation.

FlexMotion-6C generates linear interpolated moves by scaling the velocity, acceleration, deceleration, and S-curve values appropriately so that the axes assigned to the 2D/3D move will travel in a straight line in 2D or 3D space and arrive at their target positions simultaneously.

For circular, helical, and spherical arcs, the FlexMotion-6C embedded CPU calculates points along the arc segment, and the DSP performs a cubic spline algorithm that interpolates between these points. The resulting arc is extremely smooth and accurate with none of the chordal error associated with blended straight line segment approaches.

You can use FlexMotion-6C's infinite trajectory control processing to blend any arc move into another 2D or 3D arc or 2D or 3D vector straight line segment without stopping the axes involved.



Note Refer to the *FlexMotion Software Reference* for more information on circular, helical, and spherical arcs.

Analog Feedback

The FlexMotion-6C controller has an 8-channel multiplexed, 12-bit ADC. The converted analog values are broadcast to both the DSP and CPU via a dedicated internal high-speed serial bus. The multiplexer scan rates is approximately 50 μ s per enabled ADC channel. This produces the high sampling rates required for PID feedback loop closure, joystick inputs, or monitoring analog sensors.

Flash Memory

Nonvolatile memory on the FlexMotion-6C controller is implemented with flash ROM. This means that the FlexMotion-6C controller can electrically erase and reprogram its own ROM. Since all of the FlexMotion-6C controller's embedded firmware, including the RTOS and DSP code, is stored in flash memory, you can upgrade the onboard firmware contents in the field for support and new feature enhancement.

Flash memory also allows objects such as programs and data arrays to be stored in nonvolatile memory. It is possible to save the entire parameter state of the controller with the Save Default Parameters function. On the next power cycle, the FlexMotion-6C controller will automatically load and return the configuration to these new saved default values.

The FPGA configuration program is also stored in the flash ROM. Upon power up, the encoder FPGA is booted with this program. This means that updates to the FPGA program can be performed in the field.

A flash memory download utility is included with the FlexMotion software, which ships with the controller.

Axes, Motion Resources, and Vector Spaces

FlexMotion-6C can control up to six axes of motion. The axes can be completely independent, simultaneously coordinated, or mapped in multidimensional groups called vector spaces. You can also synchronize vector spaces for multi-vector space coordinated motion control.

Axes

At a minimum, an axis consists of a trajectory generator, a PID or stepper control block, and at least one output resource, either a DAC output or a stepper pulse generator output. Servo axes must have either an encoder or ADC channel feedback resource. Closed-loop stepper axes also require a feedback resource, open-loop stepper axes do not. These axis configurations are shown in Figures 4-1 and 4-2.

With FlexMotion-6C, you configure an axis with the Configure Axis Resources function. This action maps one or two feedback resources and one or two output resources to the axis. An axis with its primary output resource a stepper output is by definition a stepper axis. An axis with its primary output resource a DAC is by definition a servo axis.

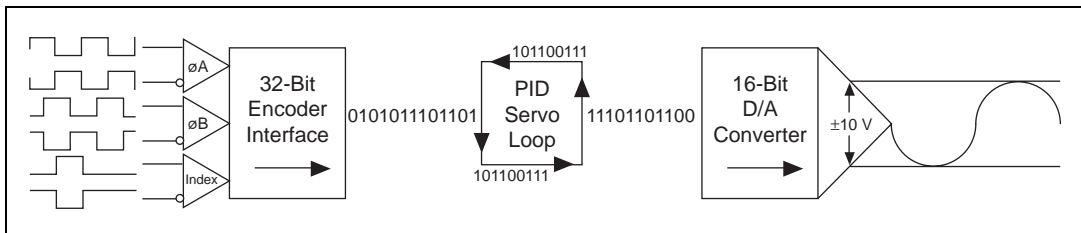

Figure 4-1. Servo Axis Resources

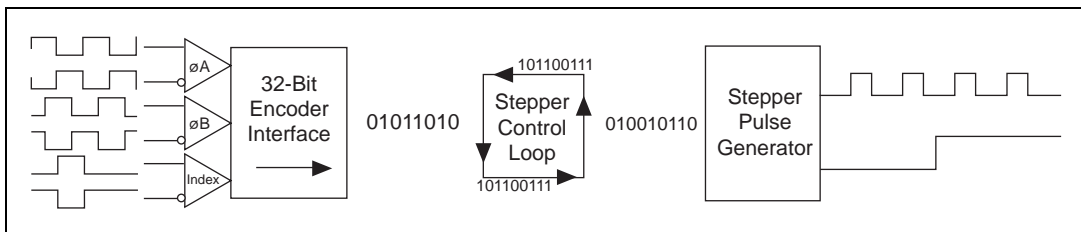

Figure 4-2. Stepper Axis Resources

In its default configuration, FlexMotion-6C comes preconfigured as six servo axes with Encoder 1 and DAC 1 mapped to Axis 1, Encoder 2 and DAC 2 mapped to Axis 2, and so on through Axis 6. However, it is simple for advanced users to map any feedback and output resource to any axis. This flexibility allows you to tailor each axis to accommodate your specific motion system requirements.



Note For many servo applications, the factory-default mapping of encoders and DACs to axes will meet your typical system requirement.

Available feedback resources are Encoder <1..6> and ADC <1..8>. Available output resources are DAC <1..6> and Stepper <5..6>.

Axes use the dedicated motion I/O signal lines assigned to them. A forward and reverse limit input, a home input, and an inhibit output are dedicated to each axis. Since there are six identical sets of these motion I/O signals, mapping is not required. If the motion I/O is not needed by the axis, you can reuse the signals as general-purpose I/O by disabling their indicated function.

FlexMotion-6C supports axes with optional secondary feedback resources (encoders or ADCs) and/or secondary output resources (DACs or stepper outputs). Two feedback resources are used when implementing dual-loop control. Defining two output resources is useful when controlling axes with multiple motors, such as gantry systems where two DAC outputs can be configured with different torque limits and/or offsets.



Note Refer to the *Axis and Resource Configuration* section of the *FlexMotion Software Reference*, for more information on configuring axes.

Motion Resources

Encoder, DAC, and ADC resources that are not used by an axis are available for nonaxis- or nonmotion-specific applications. You can directly control an unmapped DAC as a general-purpose analog output (± 10 V). Similarly, you can use any ADC channel to measure potentiometers or other analog sensors.

If an encoder resource is not needed for axis control, you can use it for any number of other functions including, position or velocity monitoring, as a digital potentiometer encoder input or as a master encoder input for master/slave, and electronic gearing applications.

Four of the six encoders feature high-speed capture trigger inputs and breakpoint outputs. These features are implemented in the encoder processor FPGA and are fully functional when an encoder is used as feedback to an axis, or as an independent input resource.



Note Once mapped to an axis, all features and functions of a resource are available as part of the axis. It is not necessary to remember or use the resource number directly when accessing these features. Resources are referenced by axis number once assigned to that axis.

Vector Spaces

Vector spaces are logical, multidimensional groups of axes. They can be either single dimensional, two dimensional with x and y axes, or three dimensional with x, y, and z axes. FlexMotion-6C supports up to three, separate one- or two-axis vector spaces (or two, three-axis vector spaces) defined at the same time.

Figure 4-3 shows a single three-axis vector space.

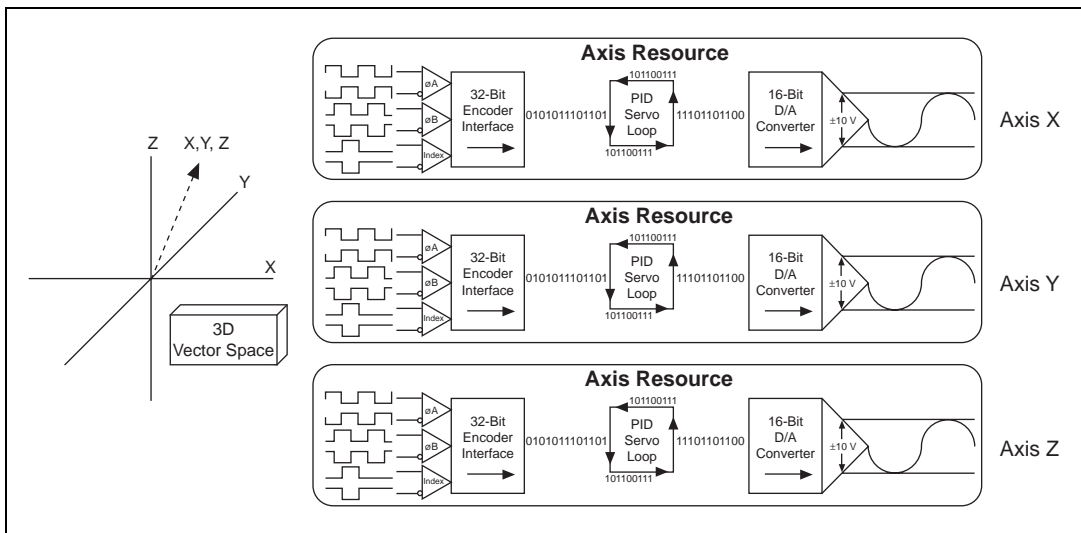

Figure 4-3. 3D Vector Space

Vector spaces facilitate 2D and 3D interpolation: linear, circular, helical and spherical. You can send many FlexMotion-6C commands to a vector space to define vector position, vector velocity, vector acceleration, and so on.

Vector spaces are configured by mapping axes to the vector space. Vector spaces are logical, not physical, and do not require motion resources other than those used by the axes themselves.



Note Refer to the *Axis and Resource Configuration* section of the *FlexMotion Software Reference*, for more information on configuring vector spaces.

Onboard Programs

FlexMotion-6C has full onboard programmability with the capability of executing up to 10 simultaneous motion programs in a real-time preemptive multitasking environment.

This extremely powerful feature is designed for real-time applications that need tight synchronization and/or minimum latency from a motion or other I/O event and fast command execution.

You can execute the entire FlexMotion function set from onboard programs. In addition, the onboard programs support basic math and data operation functions on up to 120 general-purpose variables.

Onboard programs also offer high-level, event-based functions such as Jump to Label on Condition and Wait on Condition, which allow you to sequence and make decisions in your programs. Onboard programs can even start and stop other onboard programs.

Implementing part or all of your motion application as an onboard program or programs offloads the host PC from handling these real-time tasks and events. This leaves the host PC more available for the other integrated tasks, such as data acquisition, image processing, user interface, data analysis, and/or overall measurement and automation system control.

Onboard programs can also isolate your application from the host PC's non-real-time operating system. Only the bus power is required to correctly execute an onboard FlexMotion program once it is started, and this program continues to run even if the host PC hangs, assuming the host power supply remains.

You can run onboard programs from RAM or optionally save them to flash ROM. FlexMotion-6C has 32 KB of each type of memory for program object storage. With an average command size of 10 bytes, a single program (which can be entirely stored in either RAM or ROM, but not split between both) can be as large as 3,200 commands. Conversely, the FlexMotion-6C

can simultaneously execute 10 programs, five from RAM and five from ROM, each up to 640 commands long.



Note Refer to the *Onboard Programming Functions* section of the *FlexMotion Software Reference*, for detailed information on all of these onboard programming features.

Find Home and Find Index

FlexMotion-6C features two built-in programs to aid in initializing your system and establishing a repeatable zero position reference for system-wide operation and control.

Find Home

You use the Find Home function to search for a home switch, stop on a specific edge of the switch, or optionally, go past and approach the home switch edge from a programmed direction. You can specify the initial search direction and are guaranteed to find the home switch (if one exists) because end-of-travel limit conditions are handled by reversing the home search direction.



Note Refer to the *Find Home and Index Functions* section of the *FlexMotion Software Reference*, for more information on the Find Home function.

Find Index

You can use the Find Index function to search one revolution for the Index mark of the feedback encoder. The program records the index position and returns the axis to the captured position, plus or minus an optional programmable offset. The encoder index mark is accurate to one quadrature count and provides a much more repeatable reference than a typical home switch.



Note The Find Index function is only available on closed-loop axes with quadrature encoder feedback. The encoder must provide a valid, properly phased index signal. See Figure 5-3, [Quadrature Encoder Phasing Diagram](#), for more information.

Refer to the *Find Home & Index Functions* section of the *FlexMotion Software Reference* for more information on the Find Index function.

Host Communications

The host computer communicates with a FlexMotion-6C controller through a number of I/O port addresses on the host bus. The host bus can be any of the supported bus standards—ISA or PCI.

The primary bidirectional data transfer port is at the controller's base address. This port supports FIFO data passing in both send and readback directions. The FlexMotion-6C controller has both a command buffer for incoming commands and a return data buffer (RDB) for readback data.

At address offsets from the controller's base address are two read-only status registers. The communications status register (CSR) provides bits for communications handshaking as well as real-time error reporting and general status feedback to the host PC. The move complete status (MCS) register provides instantaneous motion status of all axes.

Packets, Handshaking, and FIFO Buffers

This section briefly describes how commands and data are passed between the host computer and the FlexMotion-6C controller. This information is provided for reference purposes. The FlexMotion software that ships with the controller includes drivers, DLLs, and C function libraries that handle the host to controller communications automatically, with built-in error reporting.

Data passed to or from the FlexMotion-6C controller is handled in a packet format. A packet consists of a packet identifier word, command and data content, and a packet terminator word. This approach to communications enhances the accuracy of data communications, speeds the processing of the transferred command and data, and organizes operation into powerful, high-level motion functions.

Each word in a packet is sent over the host PC bus after checking the Ready-to-Receive (RTR) handshaking bit in the CSR. Refer to the Read Communication Status (`read_csr`) function in the *FlexMotion Software Reference* for the Status bitmap and more information on the status reported in the CSR.

Command and data packets are checked for packet format errors as the packets are received by the controller. If a packet error is detected, it is immediately reported by setting an error bit in the CSR. Once the packet is received without error, the command and data is stored in a FIFO buffer.

This FIFO can hold up to 16 commands. The FlexMotion-6C RTOS will process commands whenever it is not busy with higher priority tasks. In the unlikely occurrence that the FIFO fills up before any commands can be processed, the host detects a Not-Ready-to-Receive condition and waits for available room in the FIFO before sending additional packets.

Each command is processed and a determination is made whether to execute the command immediately, or store it away in an onboard program to be executed later. Commands are also checked for data and modal (sequence) errors at this time. A modal error is flagged by setting the error message bit in the CSR. A modal error is functionally different from the packet communication error described above. See *Error Stack* of this chapter for additional information on modal errors.

Return Data Buffer

Data or status requested by the host with a command is buffered in the return data FIFO buffer (RDB). The RDB is 26 words deep and is large enough to hold the biggest return data packet or many smaller return data packets.

When data exists in the RDB, the Ready-to-Send bit in the CSR is set. The host can then perform a bus read to get the return data from the controller.

You can use the RDB in two ways—as a temporary buffer holding a single data return packet, or as a small FIFO buffer. Typically, once the requested data is available in the RDB, it is read back by the host. It is possible however, to request a number of pieces of data and leave them in the buffer (RDB) for retrieval at a later time. The FlexMotion software supports both ways of using the RDB.

If the RDB fills up and there is no place to put requested return data, FlexMotion-6C will generate an error and set the error message bit in the CSR.



Note Refer to the *FlexMotion Software Reference* for more information on RDB buffering and readback.

Error Stack

To handle run-time or modal errors, FlexMotion-6C maintains an error stack. If an error is detected during command execution, the Command ID, Resource ID, and Error Code are placed on a last-in-first-out (LIFO) stack and the error message bit in the CSR is set.

Since commands can be buffered in the command FIFO, errors detected at command execution time are delayed and are not reported as packet errors. They are pushed on the error stack to be read back by the host at a later time. This error handling structure also correctly detects errors generated by incorrectly sequenced programs and other modal errors.

The error stack is organized as a LIFO buffer so that old errors can be ignored and the most recent error is readily available to be read with the Read Error Message function just like any other status or data value. Older errors can then be read back in the inverse order to which they were generated, and reviewed for their relevance.

The error stack can hold up to 30 errors. If the error stack fills up before any error message is read back (an unlikely event), additional error messages are thrown away.



Note Refer to the *Error Codes* section of your FlexMotion software reference for additional information on types of errors and possible reasons for their occurrence.

If the host or onboard program is correctly written, you should not see any packet or modal errors. These error-handling structures are used mostly during application development and debugging.

Signal Connections

This chapter describes how to make input and output signal connections directly to the FlexMotion-6C controller and briefly describes the associated FlexMotion-6C I/O circuitry.

The FlexMotion-6C has two connectors that handle all signals to and from the external motion system:

- 100-pin motion I/O connector
- 50-pin auxiliary 24-bit digital I/O connector

You can connect to your motion system with cables and accessories varying from simple screw terminal blocks to enhanced UMI units and drive units.



Caution Turn off power to all devices when connecting or disconnecting FlexMotion-6C motion I/O and auxiliary digital I/O cables. Failure to do so may damage the FlexMotion-6C controller.

Motion I/O Connector

The motion I/O connector contains all of the signals required to control up to six axes of servo and stepper motion including—motor command analog and stepper outputs, encoder feedback inputs, forward, home and reverse limit inputs, breakpoint outputs, trigger inputs and inhibit outputs. This connector also contains eight channels of 12-bit A/D inputs for analog feedback or general-purpose analog input.

Figure 5-1 shows the pin assignments for the 100-pin motion I/O connector on the PC-FlexMotion-6C and PCI-FlexMotion-6C controllers. A signal description follows the connector pinout. In this chapter, lines above signal names indicate that signal is active-low.

+ISO	1	51	+ISO
Axis 1 Forward Limit Input	2	52	Axis 3 Forward Limit Input
Axis 1 Home Input	3	53	Axis 3 Home Input
Axis 1 Reverse Limit Input	4	54	Axis 3 Reverse Limit Input
Trigger Input 1	5	55	Trigger Input 3
Breakpoint Output 1	6	56	Breakpoint Output 3
Axis 2 Home Input	7	57	Axis 4 Home Input
Axis 2 Forward Limit Input	8	58	Axis 4 Forward Limit Input
Trigger Input 1	9	59	Trigger Input 4
Axis 2 Reverse Limit Input	10	60	Axis 4 Reverse Limit Input
Axis 5 Forward Limit Input	11	61	ISORTN
Breakpoint Output 2	12	62	Breakpoint Output 4
Axis 5 Home Input	13	63	Analog Reference (Output)
Axis 5 Reverse Limit Input	14	64	Analog Input 1
Axis 6 Forward Limit Input	15	65	Analog Input 2
Axis 6 Reverse Limit Input	16	66	Analog Input 3
Axis 6 Home Input	17	67	Analog Input 4
E-Stop	18	68	Analog Input 5
ISORTN	19	69	Analog Input 6
Encoder 1 Phase \bar{A}	20	70	Analog Input 7
Encoder 1 Phase A	21	71	Analog Input 8
Encoder 1 Phase \bar{B}	22	72	Analog Input Ground
Encoder 1 Phase B	23	73	Analog Output 3
Encoder 1 Index	24	74	Analog Output Ground
Encoder 1 Index	25	75	Analog Output 4
Encoder 2 Phase \bar{A}	26	76	Encoder 3 Phase \bar{A}
Encoder 2 Phase A	27	77	Encoder 3 Phase A
Encoder 2 Phase \bar{B}	28	78	Encoder 3 Phase \bar{B}
Encoder 2 Phase B	29	79	Encoder 3 Phase B
Encoder 2 Index	30	80	Encoder 3 Index
Encoder 2 Index	31	81	Encoder 3 Index
Digital Ground	32	82	Encoder 4 Phase \bar{A}
Encoder 5 Phase A	33	83	Encoder 4 Phase A
Encoder 5 Phase \bar{A}	34	84	Encoder 4 Phase \bar{B}
Encoder 5 Phase B	35	85	Encoder 4 Phase B
Encoder 5 Phase \bar{B}	36	86	Encoder 4 Index
Encoder 5 Index	37	87	Encoder 4 Index
Encoder 5 Index	38	88	Digital Ground
Encoder 6 Phase A	39	89	Stepper 5 Step (CW)
Encoder 6 Phase \bar{A}	40	90	Stepper 5 Dir (CCW)
Encoder 6 Phase B	41	91	Axis 3 Inhibit
Encoder 6 Phase \bar{B}	42	92	Host +5 V
Encoder 6 Index	43	93	Stepper 6 Step (CW)
Encoder 6 Index	44	94	Stepper 6 Dir (CCW)
Digital Ground	45	95	Axis 4 Inhibit
Analog Output Ground	46	96	Digital Ground
Analog Output 1	47	97	Axis 1 Inhibit
Analog Output 2	48	98	Axis 2 Inhibit
Analog Output 5	49	99	Axis 5 Inhibit
Analog Output 6	50	100	Axis 6 Inhibit

Figure 5-1. 100-Pin Motion I/O Connector Pin Assignment

Table 5-1 describes the signals on the motion I/O connector.

Table 5-1. Motion I/O Signal Connections

Signal Name	Reference	Direction	Description
Analog Output <1..6>	Analog Output Ground	Output	Analog motor command
Analog Output Ground	—	—	Reference for Vout
Stepper <5..6> Step (CW)	Digital Ground	Output	Stepper only—motor step or clockwise control
Stepper <5..6> Dir (CCW)	Digital Ground	Output	Stepper only—motor direction or counter-clockwise control
Axis <1..6> $\overline{\text{Inhibit}}$	Digital Ground	Output	Amplifier/drive inhibit
Encoder <1..6> Phase A	Digital Ground	Input	Phase A encoder input
Encoder <1..6> Phase $\overline{\text{A}}$	Digital Ground	Input	Phase $\overline{\text{A}}$ differential encoder input
Encoder <1..6> Phase B	Digital Ground	Input	Phase B encoder input
Encoder <1..6> Phase $\overline{\text{B}}$	Digital Ground	Input	Phase $\overline{\text{B}}$ differential encoder input
Encoder <1..6> Index	Digital Ground	Input	Index or marker input
Encoder <1..6> $\overline{\text{Index}}$	Digital Ground	Input	$\overline{\text{Index}}$ or marker differential input
Digital Ground	—	—	Reference for digital I/O
Host +5 V	Digital Ground	Output	+5 V—host bus interlock
+ISO	ISORTN	Input	Isolated voltage supply
Trigger Input <1..4>	ISORTN	Input	Trigger input for high-speed capture
Breakpoint Output <1..4>	ISORTN	Output	Breakpoint output
Axis <1..6> Forward Limit Input	ISORTN	Input	Forward/clockwise limit input
Axis <1..6> Home Input	ISORTN	Input	Home input
Axis <1..6> Reverse Limit Input	ISORTN	Input	Reverse/counter-clockwise limit input
E-Stop	ISORTN	Input	Emergency Stop input
ISORTN	—	—	Reference for isolated signals
Analog Reference	Analog Input Ground	Output	7.5 V (nom.) output

Table 5-1. Motion I/O Signal Connections (Continued)

Signal Name	Reference	Direction	Description
Analog Input <1..8>	Analog Input Ground	Input	12-bit analog ADC input
Analog Input Ground	—	—	Reference for analog inputs
<hr/> Overline indicates that the signal is active-low.			

Motion Axis Signals

The following signals control the servo amplifier or stepper driver.

- Analog Output <1..6>—These 16-bit analog outputs are typically the servo command outputs for each axis. They can drive the industry-standard ± 10 V output, and can be software limited to any positive or negative voltage range desired. They also feature a software programmable voltage offset.

Although typically used as the command output of an axis control loop, unused analog outputs can also function as independent analog outputs for general-purpose control.

- Analog Output Ground—To help keep digital noise separate from the analog outputs, there is a separate return connection. You should use this analog output ground connection and not Digital Ground (digital I/O reference) as the reference for the analog outputs when connecting to servo amplifiers.
- Stepper <5..6> Step (CW) and Dir (CCW)—These open-collector signals are the stepper command outputs for each axis. The FlexMotion-6C supports both major industry standards for stepper command signals—step and direction, or independent CW and CCW pulse outputs.

The output configuration and signal polarity is software programmable for compatibility with various third-party drives.

When step and direction mode is configured, each commanded step (or microstep) produces a pulse on the step output. The direction output signal level indicates the command direction of motion, either forward or reverse.

CW and CCW mode produces pulses (steps) on the CW output for forward-commanded motion and pulses on the CCW output for reverse-commanded motion.

In either case, you can set the active polarity of both outputs to active-low (inverting) or active-high (non-inverting). For example, with step and direction, you can make a logic high correspond to either forward or reverse direction.

The Step (CW) and Dir (CCW) outputs are driven by high-speed, open-collector TTL buffers that feature high sink current capability.



Caution Do not connect these outputs to anything other than a +5 V circuit. The output buffers will fail if subjected to voltages in excess of +5.5 V.

- Axis <1..6> $\overline{\text{Inhibit}}$ —Use the inhibit output signals to control the enable/inhibit function of a servo amplifier or stepper driver. When properly connected and configured, the inhibit function causes the connected motor to be de-energized and its shaft turns freely. These open-collector inhibit signals feature high current sink capability and can directly drive most driver/amplifier inhibit input circuits. They are protected from excessive pull-up voltage with a diode clamp to internal +12 V.

While the industry standard for inhibits is active-low (inverting), these outputs have programmable polarity and can be set to active-high (non-inverting) for increased flexibility and unique drive compatibility.

Inhibit output signals are activated automatically upon a Kill Motion command or any motion error that causes a kill motion condition (for example, following error trip). You can also directly control the inhibit output signals to enable or disable a driver or amplifier.

Limit and Home Inputs

The following signals control limit and home inputs:

- Axis <1..6> Forward Limit Input
- Axis <1..6> Home Input
- Axis <1..6> Reverse Limit Input

These optoisolated inputs are typically connected to limit switches located at physical ends of travel and/or at a specific home position. Limit and home inputs may be software enabled and disabled at any time. When enabled, an active transition on a limit or home input causes a full torque halt stop of the associated motor axis. In addition, an active forward or

reverse limit input will impede future commanded motion in that direction for as long as the signal is active.



Note While limit and home transitions are edge-detected and always stop motion, active signals should remain active to prevent motion from proceeding further into the limit. Pulsed limit signals will stop motion but they do not prevent further motion in that direction.

The input polarity of these signals is software programmable for active-low (inverting) or active-high (non-inverting).

You can use software disabled limit and home inputs as general-purpose inputs. You can read the status of these inputs at any time and set and change their polarity as required.

Limit and home inputs are a per axis enhancement on the FlexMotion-6C controllers and are not required for basic motion control. These inputs are part of a system solution for complete motion control. All motion control functions may be operated without limit switches except the Find Home function, which requires enabled limit and home inputs for operations.



Note Both limits and home inputs must be enabled to use the Find Home function.

During Find Home function execution, the first active limit signal in the search direction will not simply stop the motor, but will cause motion to turn around and travel in the opposite direction and continue to search for the home switch.

Similarly, during Find Home, you can use a home switch to either stop motion or to begin a predetermined sequence of homing moves to find the correct edge of the home switch and to approach it from the desired direction.



Note After a Find Home sequence is complete, the home input should be disabled since it is no longer required assuming you do not want to stop on it the next time the system moves past it.

Wiring Concerns



Caution For the end of travel limits to function correctly, the forward limit must be located at the forward or positive end of travel and the reverse limit at the negative end of travel. Failure to do so may result in motion that stops at, but then travels through, a limit, potentially damaging the motion system. Miswired limits may prevent motion from occurring at all.

Keep limit and home switch signals and their ground connections wired separately from the motor driver/amplifier signal and encoder signal connections. Wiring these signals near each other can cause faulty motion system operation.

Limit and Home Input Circuit

Figure 5-2 shows a simplified schematic diagram of the circuit used by the limit and home switch inputs for input signal isolation.

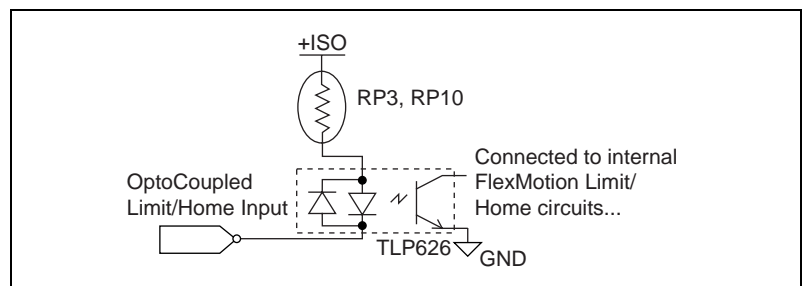

Figure 5-2. Limit and Home Input Circuit



Note See [Selecting an Isolated External/Internal Voltage Supply Configuration](#) in Chapter 3, [Hardware Overview](#), for information on selecting appropriate DIP resistor values.



Caution Excessive input voltages can cause erroneous operation and/or component failure. Verify that your input voltage is within the specification range.

Encoder Signals

FlexMotion-6C offers six channels of differential or single-ended quadrature encoder inputs:

- Encoder <1..6> Phase A
- Encoder <1..6> Phase \bar{A}
- Encoder <1..6> Phase B
- Encoder <1..6> Phase \bar{B}

The encoder inputs provide position and velocity feedback for absolute and relative positioning of axes in any motion system configuration.

If an encoder resource is not needed for axis control, it is available for other functions including position or velocity monitoring, digital potentiometer encoder inputs, or as a master encoder input for master/slave, or electronic gearing applications.

The first four encoder channels (Encoder <1..4>) are implemented in a FPGA and are high performance with extended input frequency response and advanced features such as trigger inputs and breakpoint outputs. Encoders 1 and 2 have a maximum count frequency of 16 MHz while Encoders 3 and 4 are limited to 1 MHz.

Encoders 5 and 6 have a maximum count frequency of 2 MHz, but do not offer the trigger or breakpoint functionality.

Since you can map any encoder to any axis, this variation of performance and features across the six encoder channels results in a extremely flexible architecture that can be tailored to any motion application requirement.

An encoder input channel converts quadrature signals on Phase A and Phase B into 32-bit up/down counter values. Quadrature signals are generated by optical, magnetic, laser, or electronic devices that provide two signals, Phase A and Phase B, that are 90° out of phase. The leading phase, A or B, determines the direction of motion. The four transition states of the relative signal phases provide distinct pulse edges that cause count up or count down pulses in the direction determined by the leading phase.

A typical encoder with a specification of N (N = number) lines per unit of measure (revolutions or linear distance) will produce $4 \times N$ quadrature counts per unit of measure. The count is the basic increment of position in FlexMotion systems.



Note Determine quadrature counts by multiplying the encoder resolution in encoder lines by 4. The encoder resolution is the number of encoder lines between consecutive encoder indexes (marker or Z-bit). If the encoder does not have an index output, the resolution would be referred to as lines per revolution, or lines per unit of measure (inch, centimeter, millimeter, and so on).

- Encoder <1..6> Index
- Encoder <1..6> Index

The Index input is primarily used with the Find Index function. This function uses the number of counts per revolution (or linear distance) to initiate a search move that locates the index position. When a valid index signal transition occurs during a Find Index sequence, the position of the index signal is captured very accurately. You then use this captured position to establish a reference zero position for absolute position control or any other motion system position reference required. Figure 5-3 shows the quadrature encoder phasing diagram.

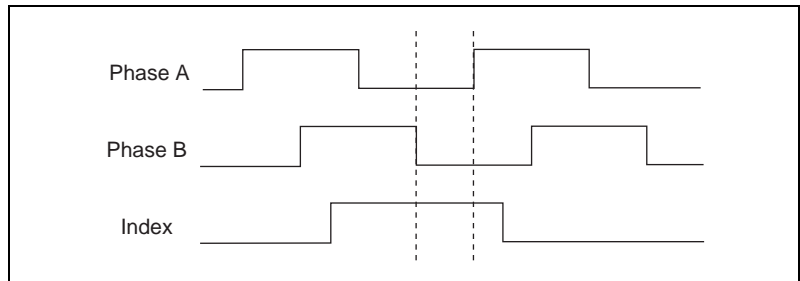

Figure 5-3. Quadrature Encoder Phasing Diagram

Wiring Concerns

The encoder inputs are connected to quadrature decoder/counter circuits. It is very important to minimize noise at this interface. Excessive noise may overwhelm the digital filters on these encoder input signals resulting in loss of counts or extra counts and erroneous closed-loop motion operation. Verify the encoder connections before powering up the system.



Caution Wire encoder signals and their ground connections separately from all other connections. Wiring these signals near the motor drive/amplifier or other signals can cause positioning errors and faulty operation.

Encoders with differential line driver outputs are strongly recommended for all applications and must be used if the encoder cable length is longer than 10 feet. Shielded, 24 AWG wire is the minimum recommended size for the encoder cable. Cables with twisted pairs and an overall shield are recommended for optimized noise immunity.



Caution Use of an unshielded cable can permit noise to corrupt the encoder signals resulting in lost counts and reduced motion system accuracy.

Encoder Input Circuit

Figure 5-4 shows a simplified schematic diagram of the circuit used for the Phase A, Phase B, and Index encoder inputs. FlexMotion-6C supports both single-ended (A, B, Index) and differential (A, \bar{A} , B, \bar{B} , Index, \bar{Index}) encoder input configurations. Both phases A and B are required for proper encoder counter operation, and the signals must support the 90° phase difference within system tolerance. The Index signal is optional but highly recommended and required for initialization functionality with the Find Index function.

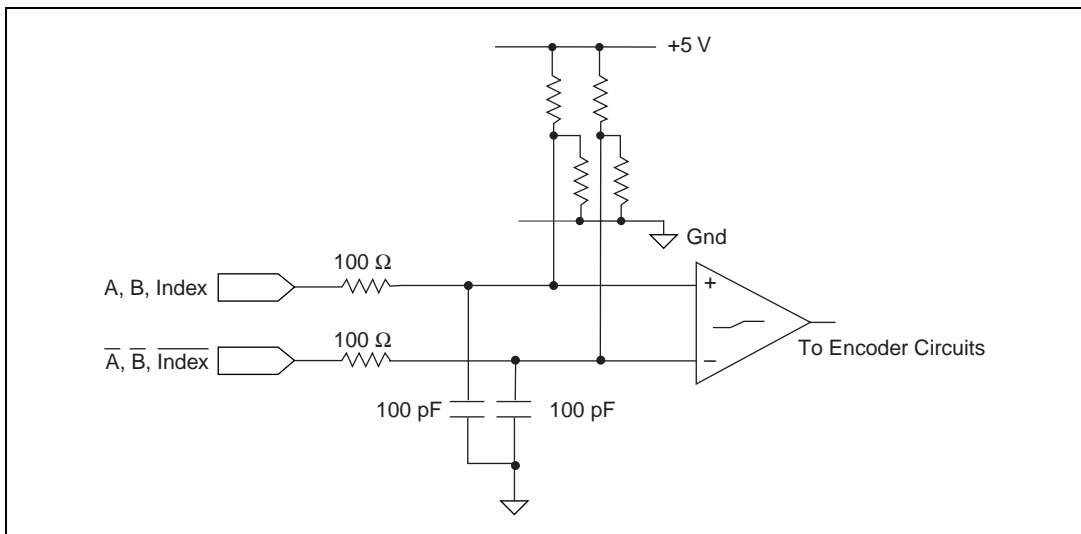

Figure 5-4. Encoder Input Circuit



Note See [Selecting Encoder Termination Networks](#) section in Chapter 3, [Hardware Overview](#), for information on selecting the appropriate SIP resistor values.

When connecting to single-ended encoder inputs, the unused differential input must be left unconnected. Connecting unused inputs to +5 V or Digital Ground will not damage the encoder input circuit but will cause faulty operation of the encoder channel.

Single-ended encoders must have TTL-compatible output drivers. Encoders with open-collector outputs can be interfaced but require you to add external 2.2 k Ω pull-up resistors to +5 V, from the encoder Phase A, B, and Index signals.

The differential nature of the encoder inputs also allows any encoder to satisfy the phasing requirements shown in Figure 5-4. Phases A and B can be swapped and/or the polarity of an individual phase can be inverted by

swapping connectors from the non-inverting (A or B) to the inverting (\overline{A} or \overline{B}) signals, or vice versa. Similarly, single-ended signals can be inverted by simply connecting them to the inverting (\overline{A} or \overline{B}) input.

Trigger Inputs and Breakpoint Outputs

FlexMotion-6C offers additional high-performance features in the encoder FPGA. The first four encoder channels have high-speed position capture trigger inputs and breakpoint outputs. These optoisolated signals are useful for high-speed synchronization of motion with actuators, sensors, and other parts of the complete motion system:

- **Trigger Input <1..4>**—When enabled, an active transition on a trigger input causes instantaneous position capture (<100 ns latency) of the corresponding encoder count value. You can use this trigger functionality for applications ranging from simple position tagging of sensor data to complex camming systems with advance/retard positioning and registration. An available FlexMotion-6C position mode is move an axis Relative to Captured Position.

The polarity of the high-speed input is programmable in software as active-low (inverting) or active-high (non-inverting). You can also use a trigger input as a latching general-purpose digital input by simply ignoring the captured position. The trigger functions as a one-shot and must be enabled appropriately.

- **Breakpoint Output <1..4>**—A breakpoint output can be programmed to transition when the associated encoder value equals the breakpoint position. You can use a breakpoint output to directly control actuators or as a trigger to synchronize data acquisition or other functions in the motion control system.

You can program breakpoints as either Absolute, Modulo, or Relative position. Breakpoints are one-shot and must be enabled and re-enabled each time they occur to function properly. The Enable Breakpoint function also allows you to preset the breakpoint output to a known state so that the transition when the breakpoint occurs can be low to high, high to low, or toggle.

You can read the status of the breakpoint function at any time. When a breakpoint is enabled, its corresponding status bit is reset to FALSE and its status goes TRUE when the breakpoint occurs.



Note The Read Breakpoint Status function does not return the digital I/O value of the breakpoint outputs; it returns the enabled/occurred status instead.

You can directly set and reset breakpoint outputs so you can use them as general-purpose digital outputs.

Wiring Concerns



Caution Keep trigger input and breakpoint output signals and their ground connections wired separately from the motor driver/amplifier signal and encoder signal connections. Wiring these signals near each other can cause faulty operation.

Excessive input voltages can cause erroneous operation and/or component failure.

Trigger Input and Breakpoint Output Circuits

Figures 5-5 and 5-6 show a simplified schematic diagram of the circuits used by the trigger inputs and breakpoint outputs for signal isolation. The trigger inputs use optocouplers rated in excess of 10 MHz to provide minimum latency on these signals.

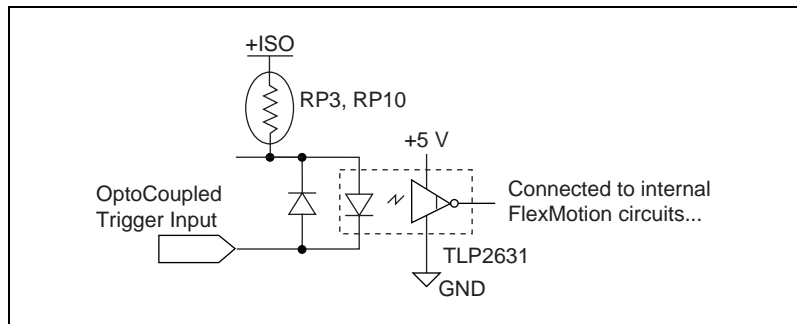

Figure 5-5. Trigger Input Circuit

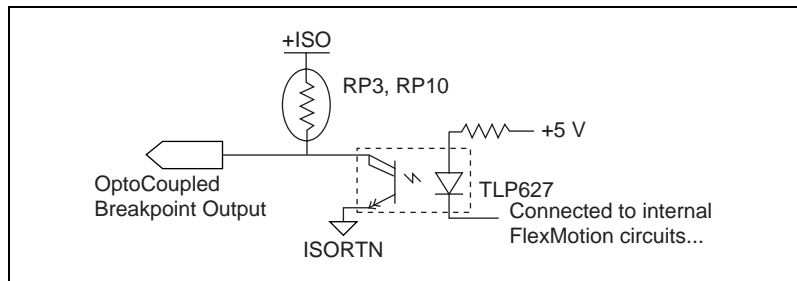

Figure 5-6. Breakpoint Output Circuit



Note See [Selecting an Isolated External/Internal Voltage Supply Configuration](#) in Chapter 3, [Hardware Overview](#), for information on selecting the appropriate DIP resistor value.

Analog Inputs

FlexMotion-6C has the following ADC input signals:

- **Analog Input <1..8>**—FlexMotion-6C includes an eight channel multiplexed, 12-bit ADC capable of measuring ± 10 V inputs. You can configure each ADC channel for motion feedback, simple A/D conversion, or both.

You can read back the digital value of analog voltage on any of the controller's eight ADC channels by using the Read ADC function. The values read back will be in the range of -2048 to 2047 (± 11 bits) with a voltage resolution of 0.0049 V per LSB (least significant bit).

When configured as analog feedback, an analog sensor acts like a limited-range, absolute-position device with a full-scale position range of ± 2048 counts. You can map any ADC channel as feedback to any axis.

You can enable and disable individual ADC channels in software. You should disable unused ADC channels for the highest multiplexer scan rate performance. Properly enabled, the scan rate is high enough to support analog feedback at the highest PID sample rate.

- **Analog Reference**—For convenience, 7.5 V (nominal) analog reference voltage is made available. You can use this output as a low current supply to sensors that require a stable reference.
- **Analog Input Ground**—To help keep digital noise out of the analog input, there is a separate return connection is provided. You should use this analog input ground connection and not Digital Ground (digital I/O reference) or Analog Output Ground as the reference for the analog inputs.

Wiring Concerns

For proper use of each ADC input channel, the analog signal to be measured should be connected to the channel input and its ground reference connected to the Analog Input Ground connection.



Note If an external reference voltage is used, it must not be connected to the analog reference output, since this is an output signal only. You should, however, connect the external reference's digital ground to the Analog Input Ground pin for proper A/D reference and improved voltage measurement.

Other Motion I/O Connections

FlexMotion-6C provides other motion I/O connections as follows:

- **+ISO**—This is the external isolated voltage supply input used to power all of the optoisolated I/O circuitry when an external isolated voltage supply is selected.

When the internal +5 V supply is selected, this signal is connected to the host computer's +5 V supply through a thermally resettable fuse. In this configuration, the I/O circuits are non-isolated and up to 0.5 A is available at this connection to power external sensors and devices.

- **ISORTN**—This is the current return connection for the external isolated voltage supply. All optoisolated circuitry is referenced to this signal connection.



Note See *Selecting an Isolated External/Internal Voltage Supply Configuration* in Chapter 3, *Hardware Overview*, for further information on how to use the +ISO and ISORTN connections.

- **Host +5 V**—This is the host computer's internal +5 V supply. It is used to detect when the host computer is powered and as an interlock to shut down external motion system components when the host computer is turned off.



Caution The host +5 V signal is limited to <100 mA and should not be used to power any external devices, except those intended in the host bus monitor circuits on the UMI and drive units.

- **E-Stop**—The optoisolated Emergency Stop input signal, when enabled in software, can be used to kill all motion by zeroing the analog outputs and freezing the stepper pulse and/or direction outputs.

Auxiliary 24-Bit Digital I/O Connector

All of FlexMotion-6C's general-purpose digital I/O lines are available on a separate 50-pin box header connector. The pinout of the connector and electrical characteristics of the I/O signals follow the OPTO 22 type standard. Each output circuit can sink 24 mA and source 3 mA. Through a standard 50-pin ribbon cable, the 24 bits of digital I/O can be directly interfaced to industry-standard signal conditioning racks with relays, optoisolated I/O, or special function modules, including the National Instruments 6B Series signal conditioning devices.

Figure 5-7 gives the pinout of the auxiliary 24-bit digital I/O connector.

Port 3:bit 7	1	2	Digital Ground
Port 3:bit 6	3	4	Digital Ground
Port 3:bit 5	5	6	Digital Ground
Port 3:bit 4	7	8	Digital Ground
Port 3:bit 3	9	10	Digital Ground
Port 3:bit 2	11	12	Digital Ground
Port 3:bit 1	13	14	Digital Ground
Port 3:bit 0	15	16	Digital Ground
Port 2:bit 7	17	18	Digital Ground
Port 2:bit 6	19	20	Digital Ground
Port 2:bit 5	21	22	Digital Ground
Port 2:bit 4	23	24	Digital Ground
Port 2:bit 3	25	26	Digital Ground
Port 2:bit 2	27	28	Digital Ground
Port 2:bit 1	29	30	Digital Ground
Port 2:bit 0	31	32	Digital Ground
Port 1:bit 7	33	34	Digital Ground
Port 1:bit 6	35	36	Digital Ground
Port 1:bit 5	37	38	Digital Ground
Port 1:bit 4	39	40	Digital Ground
Port 1:bit 3	41	42	Digital Ground
Port 1:bit 2	43	44	Digital Ground
Port 1:bit 1	45	46	Digital Ground
Port 1:bit 0	47	48	Digital Ground
+5 V	49	50	Digital Ground

Figure 5-7. 50-Pin Digital I/O Connector Pin Assignments

The 24-bit digital I/O port is configured in hardware as three 8-bit digital I/O ports, as shown in Figure 5-8. The bits in a port are typically controlled and read with byte-wide bitmapped commands.

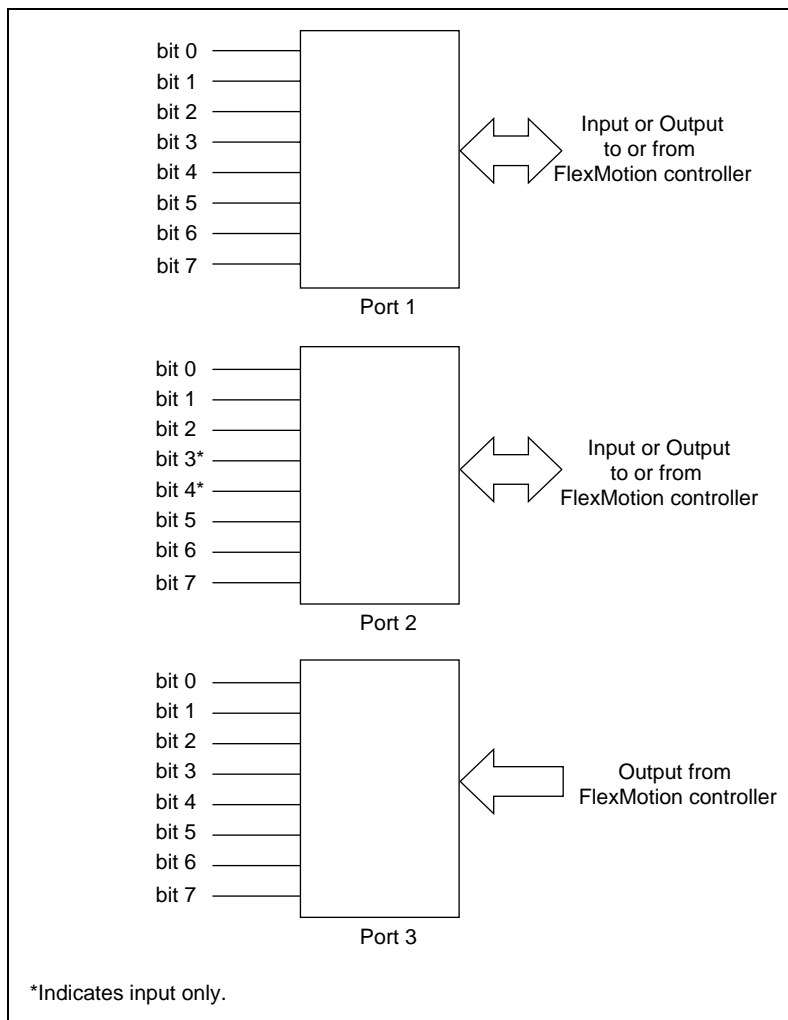

Figure 5-8. Auxiliary 24-Bit Digital I/O Port Configuration

Each port has different characteristics and features that you can configure and access through software. Port 1 is bidirectional and can be configured as a byte wide (8-bit) input or output port. All bits in the port follow this directional configuration.

Port 2 is also bidirectional, but I/O bits 3 and 4 are input only. If port 2 is configured as outputs, you cannot use bits 3 and 4.

Port 3 is a dedicated output port and the bits in it cannot be used as inputs.

With all three ports configured as outputs, you have 22 output bits. I/O bits 3 and 4 in port 2 are input only and are not usable. Conversely, it is possible to configure the ports for a maximum of 16 inputs and eight outputs.

All ports have bitwise programmable polarity and you can configure each bit as active-low (inverting) or active-high (non-inverting). Software commands that read and write the port use logical values (TRUE/FALSE) for each bit. Depending upon the programmed polarity for a bit, a TRUE value may correspond to a high voltage (active-high) or low voltage (active-low) on the physical pin.

Reads from input pins always return the logic value of the input bits. Writes to input pins do nothing. Writes to output pins set/reset the logic levels of the output bits. Reads from output pins return the logic levels last written to the port.

FlexMotion software supports the MustOn/MustOff (MOMO) protocol for setting and resetting the output bits in a port. The MOMO approach allows you to define which bits must be On (active), which bits must be Off (non-active), and which bits you want to stay in the same state. In this way, an individual bit or bits can be set or reset without worrying about the values of the other bits in the port. Of course, the entire port can also be set or reset at any time.

PWM Features

FlexMotion-6C offers a couple of special features on the 24-bit digital I/O connector. You can configure the input only I/O bit 3 of port 2 as a PCLK input and the output only I/O bits 0 and 1 of port 3 as PWM outputs. When configured for their alternate functions, you cannot use these bits general-purpose digital I/O. Table 5-2 lists these alternative functions.

Table 5-2. Enhanced I/O Features

I/O Bit	Port	Direction	Feature
I/O Bit 3	2	Input only	General-Purpose input (or) PCLK input
I/O Bit 0	3	Output only	General-purpose output (or) PWM1 Output
I/O Bit 1	3	Output only	General-purpose output (or) PWM2 Output

The two PWM outputs generate periodic waveforms whose period and duty cycles may be independently controlled through software commands. You can think of PWM as a digital representation of an analog value because the duty cycle is directly proportional to the desired output value. PWM outputs are typically used for transmitting an analog value through an optocoupler. A simple lowpass filter will turn a PWM signal back into its corresponding analog value.

You can use the PCLK input instead of the internal source as the clock for the PWM generators.

The programmable polarity of these bits is in effect whether or not you are using them for their alternative features or as general-purpose digital I/O.



Specifications

This appendix lists the hardware and software performance specifications for the FlexMotion-6C controller.

Servo Performance

PID update rate range.....	62.5 to 500 μ s/sample
Max PID update rate	62.5 μ s/axis
6 axis PID update rate	375 μ s total
Trajectory update rate	Same as PID update rate
Multi-axis synchronization	< 1 update sample
Position accuracy	
Encoder feedback.....	± 1 quadrature count
Analog feedback	± 1 LSB
Long-term velocity accuracy	Oscillator based, ± 100 ppm
Double-buffered trajectory parameters	
Absolute position range	$\pm 2^{31}$ counts
Max relative move size	$\pm 2^{31}$ counts
Velocity range.....	1 to $\pm 16,000,000$ counts/s
RPM range	10^{-5} to 10^6 revolutions/minute
Acceleration/deceleration	4,000 to 128,000,000 counts/s ²
RPS/s range.....	10^{-1} to 10^8 revolutions/s ²
S-Curve time range	1 to 32,767 samples
Following error range	0 to 32,767 counts
Gear ratio	$\pm 32,767:1$ to $1:32,767$
Servo control loop modes	PID, PIVff, S-Curve, Dual Loop
PID (Kp, Ki and Kd) gains	0 to 32,767
Integration limit (Ilim)	0 to 32,767
Derivative sample period (Td).....	1 to 63 samples

Feedforward (Aff, Vff) gains0 to 32,767

Velocity feedback (Kv) gain0 to 32,767

Servo command analog outputs

Voltage range..... ± 10 V

Resolution.....16 bits (0.000305 V/ LSB)

Programmable torque (velocity) limits

Positive limit ± 10 V ($-32,768$ to $+ 32,767$)

Negative limit ± 10 V ($-32,768$ to $+ 32,767$)

Programmable offset ± 10 V ($-32,768$ to $+ 32,767$)

Stepper Performance

Trajectory update rate range125 to 500 μ s/sample

Max update rate125 μ s/axis

Multi-axis synchronization< 1 update sample

Position accuracy

Open-loop stepper1 full, half, or microstep

Encoder feedback ± 1 quadrature count

Analog feedback..... ± 1 LSB

Long-term velocity accuracyOscillator based, ± 100 ppm

Double-buffered trajectory parameters

Position range $\pm 2^{31}$ steps

Max relative move size..... $\pm 2^{31}$ steps

Velocity range1 to 1,500,000 steps/s

RPM range..... 10^{-5} to 10^6 revolutions/minute

Acceleration/deceleration4,000 to 128,000,000 steps/s²

RPS/s range 10^{-1} to 10^8 revolutions/s²

S-curve time range.....1 to 32,767 samples

Following error range0 to 32,767 counts

Gear ratio $\pm 32,767:1$ to $1:32,767$

Stepper outputs

Max pulse rate	1.5 MHz (full, half, and microstep)
Min pulse width	300 ns at 1.5 MHz
Step output mode	Step and direction or CW/CCW
Stepper outputs	Open-collector TTL
Voltage range	0 to 5 V
Output low voltage	< 0.6 V at 64 mA sink
Polarity	Programmable, active-high or active-low

System Safety

Watchdog timer function	Resets controller to startup state
Watchdog timeout	63 ms
E- Stop input	Optocoupled
Voltage range	0 to 24 V
Optocoupler	TLP626 or equivalent
Max input current	10 mA (built-in current limiting resistor)
Control	Disable all axes and command outputs

Motion I/O

Encoder inputs	Quadrature, incremental
Max count rate	
Encoders 1 and 2	16 MHz
Encoders 3 and 4	1 MHz
Encoders 5 and 6	2 MHz
Encoder signal options	Differential or single-ended: A, \overline{A} , B, \overline{B} , Index, $\overline{\text{Index}}$ per axis
Differential input threshold	± 0.3 V (typical)
Differential line receiver	MC3486 or equivalent
Voltage range	0 to 5 V
Min index pulse width	83 ns

Forward, reverse, and home inputs.....	Optocoupled
Number of inputs	18 (3 per axis)
Voltage range.....	0 to 24 V
Optocoupler	TLP626 or equivalent
Max input current	10 mA (built-in current limiting resistor)
Polarity	Programmable, active-high or active-low
Control.....	Individual enable/disable, stop on input, prevent motion, Find Home
Trigger inputs	Optocoupled
Number of inputs	4 (Encoders 1 through 4)
Voltage range.....	0 to 24 V
Optocoupler	TLP2631 or equivalent
Max input current	10 mA (built-in current limiting resistor)
Polarity	Programmable, active-high or active-low
Min pulse width.....	83 ns
Capture latency	<100 ns
Capture accuracy	1 count
Max repetitive capture rate.....	1 kHz
Breakpoint outputs.....	Optocoupled
Number of outputs	4 (Encoders 1 through 4)
Voltage range.....	0 to 24 V
Output low voltage	< 1.2 V at 50 mA sink
Output high voltage.....	open collector with built-in pull-up to +ISO (See Table 3-2)
Optocoupler	TLP627 or equivalent
Polarity	Programmable, active-high or active-low

Inhibit/enable output	Open collector
Number of outputs	6 (1 per-axis)
Voltage range	0 to 12 V
Output low voltage.....	<1.1 V at 100 mA sink
Buffer	MC1413 or equivalent
Polarity	Programmable, active-high or active-low
Control	MustOn/mustOff or automatic when axis off

Analog inputs

Number of inputs	8, multiplexed
Voltage range	± 10 V
Input resistance	20 k Ω min
Resolution	12-bit (0.0049 V/LSB)
Analog reference output.....	7.5 V (nominal)
Reference drift	25 ppm/ $^{\circ}$ C type
Error	
Positive full-scale error.....	± 2.5 LSB max
Bipolar zero error.....	± 4 LSB max
Negative full-scale error	± 2 LSB max
Relative accuracy	± 1 LSB
Conversion time	10 μ s
Multiplexor scan rate	50 μ s/enabled channel
Converter	AD7890-10 or equivalent

Analog outputs

Number of outputs	6
Voltage range	± 10 V
Output current	± 10 mA
Resolution	16 bits (0.000305 V/LSB)
Settling time	1 μ s (1 LSB step)
Gain accuracy	$\pm 2\%$
Drift.....	25 ppm/ $^{\circ}$ C type

24-Bit Digital I/O

Ports	3, 8-bit ports
Line direction.....	individual bit programmable
Max number of input ports	2
Max number of output ports	3
Inputs	
Voltage range.....	0 to 5 V
Input low voltage.....	0.8 V
Input high voltage.....	2.0 V
Polarity	Programmable, active-high or active-low
Outputs	
Voltage range.....	0 to 5 V
Output low voltage	< 0.5 V at 24 mA sink
Output high voltage	> 2.4 V at 3 mA source
Polarity	Programmable, active-high or active-low
PWM outputs	
Number of PWM outputs	2
Max PWM frequency	32 kHz
Resolution.....	8-bit
Duty cycle range.....	0 to (255/256)%
Clock sources	Internal or external counter input

Power Requirements (Max)

+5 V ($\pm 3\%$).....	2.0 A
+12 V ($\pm 3\%$).....	150 mA
-12 V ($\pm 3\%$).....	200 mA
Power consumption	14.2 W

Physical

Dimensions (Not Including Connectors)

PC-FlexMotion-6C..... 33.8 by 9.9 cm (13.3 by 3.9 in.)

PCI-FlexMotion-6C 31.2 by 9.9 cm (12.3 by 3.9 in.)

Connectors

Motion I/O connector..... 100-pin female high density metal shell D-type

Auxiliary 24-bit digital I/O connector ... 50-pin male box header

Serial port connector 10-pin male box header

Environment

Operating temperature..... 0 to 55 °C

Storage temperature -20 to 70 °C

Relative humidity range 10 to 90% (noncondensing)

Cable Connector Descriptions

This appendix describes the connector pinout for the cables that connect to your FlexMotion controllers.

Figures B-1 and B-2 show the pin assignment for the two 50-pin connectors on the R1005050 cables. This cable splits the 100-pin motion I/O signals into two 50-pin groups for easy interfacing to industry-standard 50-pin terminal blocks.

Notice that the first 50-pin group is a complete 4-axis subsystem with all of the required inputs and outputs for motion control. In many applications, you do not need any of the signals in the second 50-pin group and only one 50-pin screw terminal block is required. For more information on signal features and capabilities, please refer to Chapter 5, *Signal Connections*.

+ISO	1	2	Axis 1 Forward Limit Input
Axis 1 Home Input	3	4	Axis 1 Reverse Limit Input
Encoder 1 Trigger Input	5	6	Encoder 1 Breakpoint Output
Axis 2 Home Input	7	8	Axis 2 Forward Limit Input
Encoder 2 Trigger Input	9	10	Axis 2 Reverse Limit Input
Axis 5 Forward Limit Input	11	12	Encoder 2 Breakpoint Output
Axis 5 Home Input	13	14	Axis 5 Reverse Limit Input
Axis 6 Forward Limit Input	15	16	Axis 6 Reverse Limit Input
Axis 6 Home Input	17	18	E-Stop
ISORTN	19	20	Encoder 1 Phase \bar{A}
Encoder 1 Phase A	21	22	Encoder 1 Phase \bar{B}
Encoder 1 Phase B	23	24	Encoder 1 Index
Encoder 1 Index	25	26	Encoder 2 Phase \bar{A}
Encoder 2 Phase A	27	28	Encoder 2 Phase \bar{B}
Encoder 2 Phase B	29	30	Encoder 2 Index
Encoder 2 Index	31	32	Digital Ground
Encoder 5 Phase A	33	34	Encoder 5 Phase \bar{A}
Encoder 5 Phase B	35	36	Encoder 5 Phase \bar{B}
Encoder 5 Index	37	38	Encoder 5 Index
Encoder 6 Phase A	39	40	Encoder 6 Phase \bar{A}
Encoder 6 Phase B	41	42	Encoder 6 Phase \bar{B}
Encoder 6 Index	43	44	Encoder 6 Index
Digital Ground	45	46	Analog Output Ground
Analog Output 1	47	48	Analog Output 2
Analog Output 5	49	50	Analog Output 6

Figure B-1. First 50-Pin Motion I/O Connector Pin Assignment

+ISO	51	52	Axis 3 Forward Limit Input
Axis 3 Home Input	53	54	Axis 3 Reverse Limit Input
Encoder 3 Trigger Input	55	56	Encoder 3 Breakpoint Output
Axis 4 Home Input	57	58	Axis 4 Forward Limit Input
Encoder 4 Trigger Input	59	60	Axis 4 Reverse Limit Input
ISORTN	61	62	Encoder 4 Breakpoint Output
Analog Reference (Output)	63	64	Analog Input 1
Analog Input 2	65	66	Analog Input 3
Analog Input 4	67	68	Analog Input 5
Analog Input 6	69	70	Analog Input 7
Analog Input 8	71	72	Analog Input Ground
Analog Output 3	73	74	Analog Output Ground
Analog Output 4	75	76	Encoder 3 Phase \bar{A}
Encoder 3 Phase A	77	78	Encoder 3 Phase \bar{B}
Encoder 3 Phase B	79	80	Encoder 3 Index
Encoder 3 Index	81	82	Encoder 4 Phase \bar{A}
Encoder 4 Phase A	83	84	Encoder 4 Phase \bar{B}
Encoder 4 Phase B	85	86	Encoder 4 Index
Encoder 4 Index	87	88	Digital Ground
Stepper 5 Step (CW)	89	90	Stepper 5 Dir (CCW)
Axis 3 Inhibit	91	92	Host +5 V
Stepper 6 Step (CW)	93	94	Stepper 6 Dir (CCW)
Axis 4 Inhibit	95	96	Digital Ground
Axis 1 Inhibit	97	98	Axis 2 Inhibit
Axis 5 Inhibit	99	100	Axis 6 Inhibit

Figure B-2. Second 50-Pin Motion I/O Connector Pin Assignment



Technical Support Resources

This appendix describes the comprehensive resources available to you in the Technical Support section of the National Instruments Web site and provides technical support telephone numbers for you to use if you have trouble connecting to our Web site or if you do not have internet access.

NI Web Support

To provide you with immediate answers and solutions 24 hours a day, 365 days a year, National Instruments maintains extensive online technical support resources. They are available to you at no cost, are updated daily, and can be found in the Technical Support section of our Web site at www.natinst.com/support.

Online Problem-Solving and Diagnostic Resources

- **KnowledgeBase**—A searchable database containing thousands of frequently asked questions (FAQs) and their corresponding answers or solutions, including special sections devoted to our newest products. The database is updated daily in response to new customer experiences and feedback.
- **Troubleshooting Wizards**—Step-by-step guides lead you through common problems and answer questions about our entire product line. Wizards include screen shots that illustrate the steps being described and provide detailed information ranging from simple getting started instructions to advanced topics.
- **Product Manuals**—A comprehensive, searchable library of the latest editions of National Instruments hardware and software product manuals.
- **Hardware Reference Database**—A searchable database containing brief hardware descriptions, mechanical drawings, and helpful images of jumper settings and connector pinouts.
- **Application Notes**—A library with more than 100 short papers addressing specific topics such as creating and calling DLLs, developing your own instrument driver software, and porting applications between platforms and operating systems.

Software-Related Resources

- **Instrument Driver Network**—A library with hundreds of instrument drivers for control of standalone instruments via GPIB, VXI, or serial interfaces. You also can submit a request for a particular instrument driver if it does not already appear in the library.
- **Example Programs Database**—A database with numerous, non-shipping example programs for National Instruments programming environments. You can use them to complement the example programs that are already included with National Instruments products.
- **Software Library**—A library with updates and patches to application software, links to the latest versions of driver software for National Instruments hardware products, and utility routines.

Worldwide Support

National Instruments has offices located around the globe. Many branch offices maintain a Web site to provide information on local services. You can access these Web sites from www.natinst.com/worldwide.

If you have trouble connecting to our Web site, please contact your local National Instruments office or the source from which you purchased your National Instruments product(s) to obtain support.

For telephone support in the United States, dial 512 795 8248. For telephone support outside the United States, contact your local branch office:

Australia 03 9879 5166, Austria 0662 45 79 90 0, Belgium 02 757 00 20,
Brazil 011 284 5011, Canada (Ontario) 905 785 0085,
Canada (Québec) 514 694 8521, China 0755 3904939,
Denmark 45 76 26 00, Finland 09 725 725 11, France 01 48 14 24 24,
Germany 089 741 31 30, Hong Kong 2645 3186, India 91805275406,
Israel 03 6120092, Italy 02 413091, Japan 03 5472 2970,
Korea 02 596 7456, Mexico (D.F.) 5 280 7625,
Mexico (Monterrey) 8 357 7695, Netherlands 0348 433466,
Norway 32 27 73 00, Singapore 2265886, Spain (Madrid) 91 640 0085,
Spain (Barcelona) 93 582 0251, Sweden 08 587 895 00,
Switzerland 056 200 51 51, Taiwan 02 2377 1200,
United Kingdom 01635 523545

Glossary

Prefix	Meaning	Value
p-	pico-	10^{-12}
n-	nano-	10^{-9}
μ -	micro-	10^{-6}
m-	milli-	10^{-3}
k-	kilo-	10^3
M-	mega-	10^6

Numbers/Symbols

°	degrees
%	percent
±	plus or minus
+	positive of, or plus
-	negative of, or minus
/	per
Ω	ohm
%	percent
+5 V	+5 VDC source signal

A

A	amperes
absolute mode	treat the target position loaded as position relative to zero (0) while making a move

absolute position	position relative to zero
acceleration/ deceleration	a measurement of the change in velocity as a function of time. Acceleration and deceleration describes the period when velocity is changing from one value to another.
active-high	a signal is active when its value goes high (1)
active-low	a signal is active when its value goes low (0)
A/D	analog-to-digital
address	character code that identifies a specific location (or series of locations) in memory or on a host PC bus system
amplifier	the drive that delivers power to operate the motor in response to low level control signals. In general, the amplifier is designed to operate with a particular motor type—you cannot use a stepper drive to operate a DC brush motor, for instance
Analog Input <1..8>	12-bit analog ADC input
Analog Output <1..6>	DAC voltage output
API	application programming interface
axis	unit that controls a motor or any similar motion or control device
Axis <1..6> <u>Inhibit</u>	axis 1 through 6 inhibit output
Axis <1..6> Forward Limit Input	axis 1 through 6 forward/clockwise limit switch
Axis <1..6> Home Input	axis 1 through 6 home input
Axis <1..6> Reverse Limit Input	axis 1 through 6 reverse/counter-clockwise limit input
B	
b	bit—one binary digit, either 0 or 1
base address	memory address that serves as the starting address for programmable or I/O bus registers. All other addresses are located by adding to the base address.

binary	a number system with a base of 2
buffer	temporary storage for acquired or generated data (software)
bus	the group of conductors that interconnect individual circuitry in a computer. Typically, a bus is the expansion vehicle to which I/O or other devices are connected.
byte	eight related bits of data, an eight-bit binary number. Also used to denote the amount of memory required to store one byte of data.

C

CCW	counter-clockwise—implies direction of rotation of the motor
closed-loop	a motion system that uses a feedback device to provide position and velocity data for status reporting and accurately controlling position and velocity
CPU	central processing unit
crosstalk	an unwanted signal on one channel due to an input on a different channel
CW	clockwise—implies direction of motor rotation

D

DC	direct current
dedicated	assigned to a particular function
DGND	digital ground signal
digital ground	reference signal for digital I/O
digital I/O port	a group of digital input/output signals
DIP	dual inline package
DLL	dynamic link library—provides the API for the motion control controllers
drivers	software that communicates commands to control a specific motion control controller

E

encoder	device that translates mechanical motion into electrical signals; used for monitoring position or velocity in a closed-loop system
encoder resolution	the number of encoder lines between consecutive encoder indexes (marker or Z-bit). If the encoder does not have an index output the encoder resolution can be referred to as lines per revolution.

F

f	farad
filtering	a type of signal conditioning that filters unwanted signals from the signal being measured
filter parameters	indicates the control loop parameter gains (PID gains) for a given axis
following error trip point	the difference between the instantaneous commanded trajectory position and the feedback position
freewheel	the condition of a motor when power is de-energized and the motor shaft is free to turn with only frictional forces to impede it
full-step	full-step mode of a stepper motor—for a two phase motor this is done by energizing both windings or phases simultaneously

G

Gnd	ground
GND	ground

H

half-step	mode of a stepper motor—for a two phase motor this is done by alternately energizing two windings and then only one. In half step mode, alternate steps are strong and weak but there is significant improvement in low-speed smoothness over the full-step mode.
hex	hexadecimal

home switch (input)	a physical position determined by the mechanical system or designer as the reference location for system initialization. Frequently, the home position is also regarded as the zero position in an absolute position frame of reference.
host computer	computer into which the motion controller is plugged
I	
ID	identification
in.	inches
index	marker between consecutive encoder revolutions
I/O	input/output—the transfer of data to and from a computer system involving communications channels, operator interface devices, and/or motion control interfaces
interlock	5 V bus interlock voltage
inverting	the polarity of a switch (limit switch, home switch, etc.) in <i>active</i> state. If these switches are active-low they are said to have inverting polarity.
IRQ	interrupt request
ISA	industry standard architecture, 16-bit (AT-bus) interface standard
K	
k	kilo—the standard metric prefix for 1,000, or 10^3 , used with units of measure such as volts, hertz, and meters
K	kilo—the prefix for 1,024, or 2^{10} , used with B in quantifying data or computer memory
L	
limit switch/end-of-travel position(input)	sensors that alert the control electronics that physical end of travel is being approached and that the motion should stop

M

m	meters
microstep	The proportional control of energy in the coils of a Stepper Motor that allows the motor to move to or stop at locations other than the fixed magnetic / mechanical pole positions determined by the motor specifications. This capability facilitates the subdivision of full mechanical steps on a stepper motor into finer microstep locations that greatly smooth motor running operation and increase the resolution or number of discrete positions that a stepper motor can attain in each revolution.
modulo position	treat the target position as within the range of total quadrature counts per revolution for an axis

N

noise	an undesirable electrical signal—noise comes from external sources such as the AC power line, motors, generators, transformers, fluorescent lights, soldering irons, CRT displays, computers, electrical storms, welders, radio transmitters, and internal sources such as semiconductors, resistors, and capacitors. Noise corrupts signals you are trying to send or receive.
noninverting	the polarity of a switch (limit switch, home switch, etc.) in <i>active</i> state. If these switches are active-high, they are said to have non-inverting polarity.

O

open-loop	refers to a motion control system where no external sensors (feedback devices) are used to provide position or velocity correction signals
-----------	--

P

PID	proportional-integral-derivative control loop
PIVff	proportional-integral-velocity feed forward
port	(1) a communications connection on a computer or a remote controller (2) a digital port, consisting eight lines of digital input and/or output

position breakpoint	position breakpoint for an encoder can be set in absolute or relative quadrature counts. When the encoder reaches a position breakpoint, the associated breakpoint output immediately transitions.
power cycling	turning the host computer off and then back on, which causes a reset of a the motion controller
PWM	Pulse Width Modulation—a method of controlling the average current in a motors phase windings by varying the on-time (duty cycle) of transistor switches

Q

quadrature counts	the encoder line resolution times four
-------------------	--

R

RAM	random-access memory
relative breakpoint	sets the position breakpoint for an encoder in relative quadrature counts
relative position	The destination or target position for motion specified with respect to the current location regardless of its value.
relative position mode	position relative to current position
ribbon cable	a flat cable in which the conductors are side by side
RPM	revolutions per minute—units for velocity
RPS/PS or RPS/S	revolutions per second squared—units for acceleration and deceleration

S

s	seconds
servo	specifies an axis that controls a servo motor
stepper	specifies an axis that controls a stepper motor
stepper <5..6> Dir (CCW)	direction output or counter-clockwise direction control
stepper <5..6> Step (CW)	stepper pulse output or clockwise direction control

T

toggle	changing state from high to low, back to high, and so on
torque	force tending to produce rotation
trapezoidal profile	a typical motion trajectory, where a motor accelerates up to the programmed velocity using the programmed acceleration, traverses at the programmed velocity, then decelerates at the programmed acceleration to the target position
trigger	any event that causes or starts some form of data capture
TTL	transistor-transistor logic

V

V	volts
V _{CC}	positive voltage supply
velocity mode	move the axis continuously at the specified velocity

W

watchdog	a timer task that shuts down (resets) the motion controller if any serious error occurs
word	the standard number of bits that a processor or memory manipulates at one time, typically 8-, 16-, or 32-bit

Index

Numbers

- +5 V signal. *See* Host +5 V signal.
- +5 V supply, setting isolated supply jumpers for, 3-8 to 3-9
- 24-bit digital I/O connector. *See* auxiliary 24-bit digital I/O connector.

A

- ADC resources, 4-7
- analog feedback, 4-5
- Analog Input Ground signal
 - purpose and use, 5-13
 - reference, direction, and description (table), 5-4
- Analog Input<1..8> signal
 - purpose and use, 5-13
 - reference, direction, and description (table), 5-4
- analog inputs
 - signal descriptions, 5-13
 - wiring concerns, 5-13
- Analog Output Ground signal
 - description, 5-4
 - reference, direction, and description (table), 5-3
- Analog Output<1..6> signal
 - description, 5-4
 - reference, direction, and description (table), 5-3
- Analog Reference signal
 - purpose and use, 5-13
 - reference, direction, and description (table), 5-4
- auxiliary 24-bit digital I/O connector, 5-14 to 5-18
 - 50-pin connector pin assignments (figure), 5-15

- digital I/O port configuration (figure), 5-16
- PWM features, 5-17 to 5-18
- specifications, A-6
- axes
 - functional overview, 4-6 to 4-7
 - servo axis resources (figure), 4-6
 - stepper axis resources (figure), 4-6
- Axis <1..6> Forward Limit Input signal
 - limit and home input control, 5-5 to 5-6
 - reference, direction, and description (table), 5-3
- Axis <1..6> Home Input signal
 - limit and home input control, 5-5 to 5-6
 - reference, direction, and description (table), 5-3
- Axis <1..6> $\overline{\text{Inhibit}}$ signal
 - description, 5-5
 - reference, direction, and description (table), 5-3
- Axis <1..6> Reverse Limit Input signal
 - limit and home input control, 5-5 to 5-6
 - reference, direction, and description (table), 5-3

B

- blending moves, 4-3 to 4-4
- Breakpoint Output<1..4> signal
 - purpose and use, 5-11
 - reference, direction, and description (table), 5-3
- breakpoint outputs. *See* trigger inputs and breakpoint outputs.
- BridgeVIEW software, 1-3

C

cable connector pin assignments, B-1 to B-3
 circular interpolation, 4-4 to 4-5
 communications. *See* host communications.
 configuration
 bus-related configuration, 2-1
 motion I/O configuration, 3-7 to 3-12
 encoder termination network
 selection, 3-11 to 3-12
 isolated external/internal voltage
 supply configuration, 3-8 to 3-11
 locating isolated supply jumper block
 (JP2), 3-8
 overview, 2-1
 RP3 and RP10 DIP resistor networks,
 3-10 to 3-11
 setting isolated supply jumper block
 for internal +5 V supply, 3-8 to 3-9
 PC-FlexMotion-6C controllers, 2-2
 PCI-FlexMotion-6C controllers, 2-2
 connectors. *See also* motion I/O connector.
 auxiliary 24-bit digital I/O connector,
 5-14 to 5-18
 50-pin connector pin assignments
 (figure), 5-15
 digital I/O port configuration
 (figure), 5-16
 cable connectors, B-1 to B-3
 first 50-pin motion I/O pin
 assignments, B-2
 second 50-pin motion I/O pin
 assignments, B-3
 physical specifications, A-7
 reserved connectors (note), 3-3
 user connectors, 3-2

D

DAC resources, 4-7
 diagnostic resources, online, C-1
 Digital Ground signal (table), 5-3

digital I/O connector. *See* auxiliary 24-bit
 digital I/O connector.
 DIP resistor networks (RP3 and RP10),
 3-10 to 3-11
 motion I/O DIP resistor values
 (table), 3-11
 optocoupled motion I/O DIP resistor
 networks (figure), 3-11
 DIP switch settings. *See* ISA bus address table.
 documentation
 about the manual, *ix*
 conventions used in manual, *ix*
 related documentation, *x*
 dual processor architecture, 4-1 to 4-5

E

electronic gearing, 4-4
 embedded real time operating system (RTOS),
 4-1 to 4-2
 Encoder <1..6> Index signal
 reference, direction, and description
 (table), 5-3
 using with Find Index function, 5-8 to 5-9
 Encoder <1..6> $\overline{\text{Index}}$ signal
 reference, direction, and description
 (table), 5-3
 using with Find Index function, 5-8 to 5-9
 Encoder <1..6> Phase A signal
 quadrature encoder input, 5-7 to 5-8
 reference, direction, and description
 (table), 5-3
 Encoder <1..6> Phase $\overline{\text{A}}$ signal
 quadrature encoder input, 5-7 to 5-8
 reference, direction, and description
 (table), 5-3
 Encoder <1..6> Phase B signal
 quadrature encoder input, 5-7 to 5-8
 reference, direction, and description
 (table), 5-3

Encoder <1..6> Phase \bar{B} signal
 quadrature encoder input, 5-7 to 5-8
 reference, direction, and description
 (table), 5-3

encoder resources, 4-7

encoder signals, 5-7 to 5-11
 encoder input circuit, 5-10 to 5-11
 quadrature encoder phasing diagram, 5-9
 signal descriptions, 5-7 to 5-9
 wiring concerns, 5-9

encoder termination networks, selecting,
 3-11 to 3-12
 resistor values (table), 3-12
 SIP resistor networks (figure), 3-12

enhanced PID functions, 4-2

environment specifications, A-7

equipment, optional, 1-4

error stack, 4-13

E-Stop signal
 description, 5-14
 reference, direction, and description
 (table), 5-3

F

FIFO buffers, 4-11 to 4-12

Find Home function, 4-10, 5-6

Find Index function, 4-10, 5-9

flash memory, 4-5

FlexMotion-6C controllers. *See also*
 PC-FlexMotion-6C controller;
 PCI-FlexMotion-6C controller.

functional overview. *See* functional
 overview.

installation, 2-2 to 2-3

National Instruments application
 software, 1-3

optional equipment, 1-4

overview and features, 1-1 to 1-2. *See also*
 hardware overview.

requirements for getting started, 1-2
 software programming choices, 1-3

functional overview, 4-1 to 4-13. *See also*
 hardware overview.

analog feedback, 4-5

axes, 4-6 to 4-7

dual processor architecture, 4-1 to 4-5

embedded real time operating system
 (RTOS), 4-1 to 4-2

enhanced PID functions, 4-2

flash memory, 4-5

host communications, 4-11 to 4-13
 error stack, 4-13
 packets, handshaking, and FIFO
 buffers, 4-11 to 4-12
 return data buffer, 4-12

motion resources, 4-7 to 4-8

onboard programs, 4-9 to 4-10
 Find Home function, 4-10, 5-6
 Find Index function, 4-10, 5-9

trajectory generators, 4-2 to 4-5
 electronic gearing, 4-4
 linear and circular interpolation,
 4-4 to 4-5
 move blending, 4-3 to 4-4
 trapezoidal point-to-point position
 control, 4-3
 velocity control, 4-3

vector spaces, 4-8 to 4-9

H

handshaking, 4-11 to 4-12

hardware installation, 2-2 to 2-3

hardware overview, 3-1 to 3-12. *See also*
 functional overview.

ISA bus address table, 3-3 to 3-7
 address map (table), 3-4 to 3-7
 DIP switch settings, 3-3 to 3-4
 factory default DIP switch setting
 (figure), 3-4

- motion I/O configuration, 3-7 to 3-12
 - encoder termination network
 - selection, 3-11 to 3-12
 - isolated external/internal voltage
 - supply configuration, 3-8 to 3-11
- parts locator diagrams
 - PC-FlexMotion-6C controller, 3-1
 - PCI-FlexMotion-6C controller, 3-2
- reserved connectors (note), 3-3
- user connectors, 3-2

home inputs. *See* limit and home inputs.

Host +5 V signal

- description, 5-14
- reference, direction, and description (table), 5-3

host communications, 4-11 to 4-13

- error stack, 4-13
- packets, handshaking, and FIFO buffers, 4-11 to 4-12
- return data buffer, 4-12

I

installation of hardware, 2-2 to 2-3

I/O connectors. *See* connectors; motion I/O connector.

ISA bus address table, 3-3 to 3-7

- address map (table), 3-4 to 3-7
- DIP switch settings, 3-3 to 3-4
- factory default DIP switch setting (figure), 3-4

+ISO signal

- description, 5-14
- reference, direction, and description (table), 5-3
- setting isolated supply jumpers
 - external isolated supply, 3-9 to 3-10
 - internal +5 V supply, 3-8 to 3-9

- isolated external/internal voltage supply
 - configuration, 3-8 to 3-11
 - locating isolated supply jumper block (JP2), 3-8
 - RP3 and RP10 DIP resistor networks, 3-10 to 3-11
 - setting isolated supply jumper block for internal +5 V supply, 3-8 to 3-9

ISORTN signal

- description, 5-14
- reference, direction, and description (table), 5-3
- setting isolated supply jumpers
 - external isolated supply, 3-9 to 3-10
 - internal +5 V supply, 3-8 to 3-9

J

jumper block JP2. *See* isolated external/internal voltage supply configuration.

L

LabVIEW software, 1-3

LabWindows/CVI software, 1-3

limit and home inputs, 5-5 to 5-7

- circuit (figure), 5-7
- signal descriptions, 5-5 to 5-6
- wiring concerns, 5-7

linear and circular interpolation, 4-4 to 4-5

M

manual. *See* documentation.

MOMO (MustOn/MustOff) protocol, 5-17

motion axis signals

- Analog Output Ground, 5-4 to 5-5
- Analog Output<1..6>, 5-3, 5-4
- Axis <1..6> Inhibit signal, 5-3, 5-5
- Stepper <5..6> Dir (CCW) signal, 5-3, 5-4 to 5-5

- Stepper <5..6> Step (CW) signal, 5-3, 5-4 to 5-5
- motion I/O configuration, 3-7 to 3-12
 - encoder termination network selection, 3-11 to 3-12
 - isolated external/internal voltage supply, 3-8 to 3-11
 - locating isolated supply jumper block (JP2), 3-8
 - RP3 and RP10 DIP resistor networks, 3-10 to 3-11
 - setting isolated supply jumper block for internal +5 V supply, 3-8 to 3-9
- motion I/O connector, 5-1 to 5-14
 - analog inputs, 5-13
 - encoder signals, 5-7 to 5-11
 - limit and home inputs, 5-5 to 5-7
 - motion axis signals, 5-4 to 5-5
 - other motion I/O connections, 5-14
 - overview, 1-4, 5-1
 - pin assignments (figure), 5-2
 - signal connections (table), 5-3 to 5-4
 - specifications, A-3 to A-5
 - trigger inputs and breakpoint outputs, 5-11 to 5-12
- motion resources, 4-7 to 4-8
- move blending, 4-3 to 4-4
- MustOn/MustOff (MOMO) protocol, 5-17

N

- National Instruments Web support, C-1 to C-2

O

- onboard programs, 4-9 to 4-10
 - Find Home function, 4-10, 5-6
 - Find Index function, 4-10, 5-9
- online problem-solving and diagnostic resources, C-1
- optional equipment, 1-4

- optoisolation power supply. *See* isolated external/internal voltage supply configuration.

P

- packets, 4-11 to 4-12
- parts locator diagrams
 - PC-FlexMotion-6C controller, 3-1
 - PCI-FlexMotion-6C controller, 3-2
- PC-FlexMotion-6C controller. *See also* FlexMotion-6C controllers.
 - configuration, 2-2
 - ISA bus address table, 3-3 to 3-7
 - address map (table), 3-4 to 3-7
 - DIP switch settings, 3-3 to 3-4
 - factory default DIP switch setting (figure), 3-4
 - parts locator diagrams, 3-1
- PCI Local Bus Specification*, 2-2
- PCI-FlexMotion-6C controller. *See also* FlexMotion-6C controllers.
 - configuration, 2-2
 - parts locator diagrams, 3-2
- physical specifications
 - connectors, A-7
 - dimensions, A-7
- PID functions, enhanced, 4-2
- power requirement specifications, A-6
- problem-solving and diagnostic resources, online, C-1
- programs, onboard, 4-9 to 4-10
 - Find Home function, 4-10, 5-6
 - Find Index function, 4-10, 5-9
- PWM (pulse width modulation) and counter features, 5-17 to 5-18

R

real time operating system (RTOS),
 embedded, 4-1 to 4-2
 requirements for getting started, 1-2
 reserved connectors (note), 3-3
 return data buffer, 4-12
 RP3 and RP10 DIP resistor networks,
 3-10 to 3-11
 motion I/O DIP resistor values
 (table), 3-11
 optocoupled motion I/O DIP resistor
 networks (figure), 3-11
 RTOS (embedded real time operating system),
 4-1 to 4-2

S

safety specifications, A-3
 servo performance specifications, A-1 to A-2
 signal connections. *See* auxiliary 24-bit digital
 I/O connector; motion I/O connector.
 software
 National Instruments application
 software, 1-3
 onboard programs, 4-9 to 4-10
 software programming choices, 1-3
 software-related resources, C-2
 specifications, A-1 to A-7
 24-bit digital I/O, A-6
 environment, A-7
 motion I/O, A-3 to A-5
 physical, A-7
 power requirements (max), A-6
 servo performance, A-1 to A-2
 stepper performance, A-2 to A-3
 system safety, A-3
 Stepper <5..6> Dir (CCW) signal
 description, 5-4 to 5-5
 reference, direction, and description
 (table), 5-3

Stepper <5..6> Step (CW) signal
 description, 5-4 to 5-5
 reference, direction, and description
 (table), 5-3
 stepper performance specifications,
 A-2 to A-3
 system safety specifications, A-3

T

technical support resources, C-1 to C-2
 termination networks. *See* encoder termination
 networks, selecting.
 trajectory generators, 4-2 to 4-5
 electronic gearing, 4-4
 linear and circular interpolation,
 4-4 to 4-5
 move blending, 4-3 to 4-4
 trapezoidal point-to-point position
 control, 4-3
 velocity control, 4-3
 trapezoidal point-to-point position control, 4-3
 Trigger Input<1..4> signal
 purpose and use, 5-11
 reference, direction, and description
 (table), 5-3
 trigger inputs and breakpoint outputs,
 5-11 to 5-12
 breakpoint output circuit (figure), 5-12
 signal descriptions, 5-11
 trigger input circuit (figure), 5-12
 wiring concerns, 5-12

U

user connectors, 3-2

V

vector spaces, 4-8 to 4-9
 velocity control, 4-3

W

- Web support from National Instruments,
C-1 to C-2
 - online problem-solving and diagnostic
resources, C-1
 - software-related resources, C-2
- Worldwide technical support, C-2